

Isometric projection

Objects in simple position only

I object resting on its base on H.P.

① One base edge \parallel to V.P

② One base edge \perp to V.P

③ One base edge inclined θ° to V.P

④ 2 adjacent base edges equally inclined to V.P

II object resting on its base on V.P

① One base edge \parallel to H.P

② One base edge \perp to H.P

③ One base edge inclined θ° to H.P

④ 2 adjacent base edges equally inclined to H.P.

Isometric projection

Consider a cube

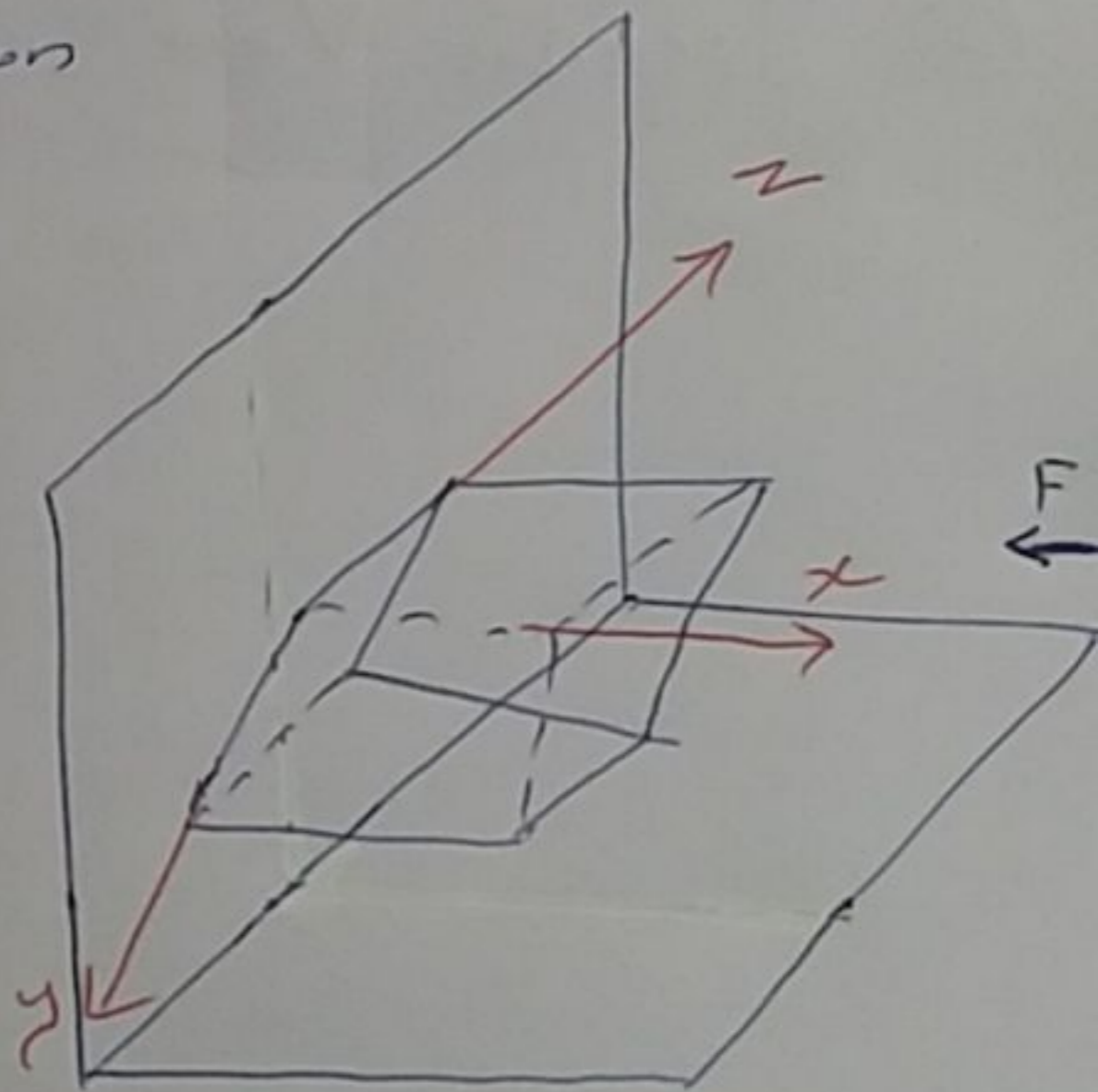
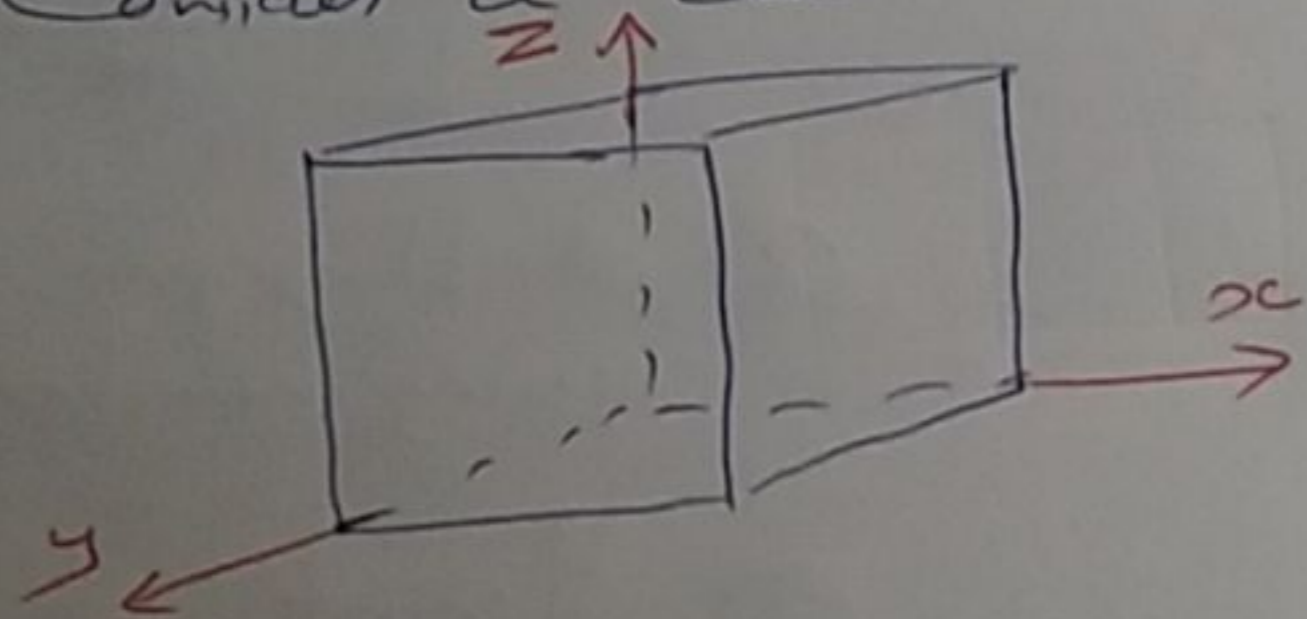

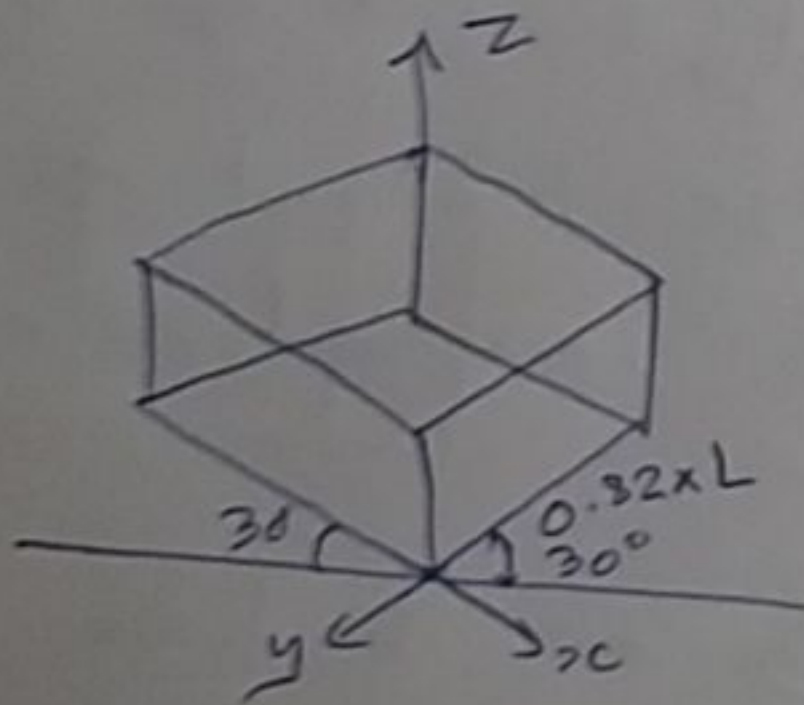
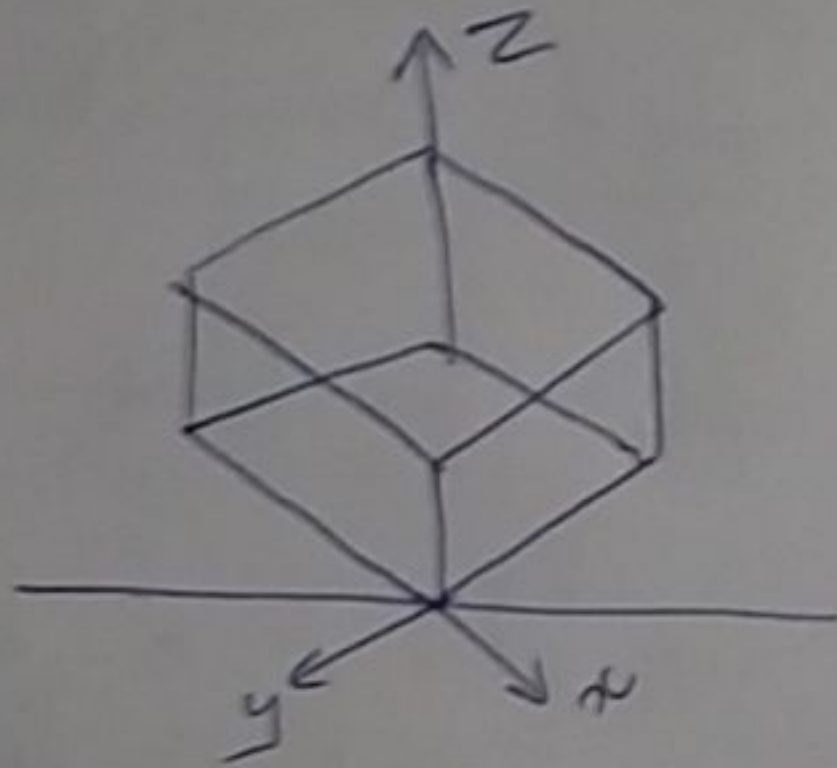

Isometric projection (edges) \Rightarrow 82% of T.L

Isometric View

Steps (T.L)

- ① Orthographic projection
- ② Isometric View

Isometric Projection

Steps (82% of T.L)

- ① Isometric Scale

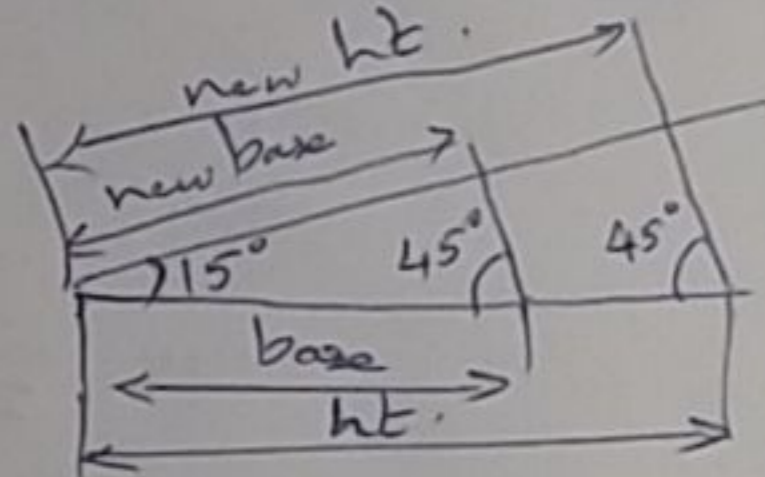

- ② Orthographic projection using new base & new ht.
- ③ Isometric projection

① When base on H.P (when crosssection is seen in top view)

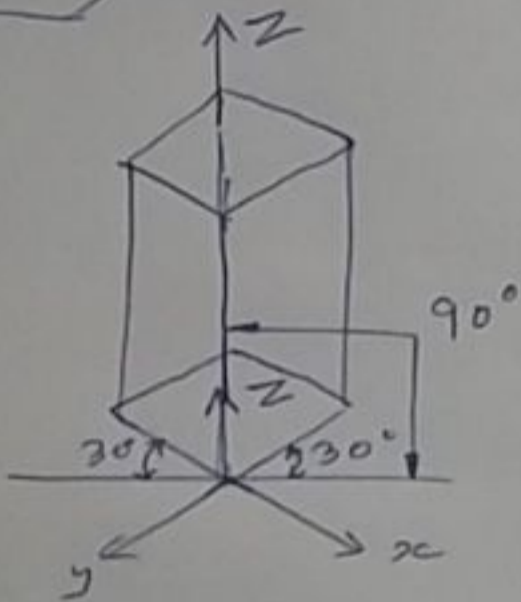
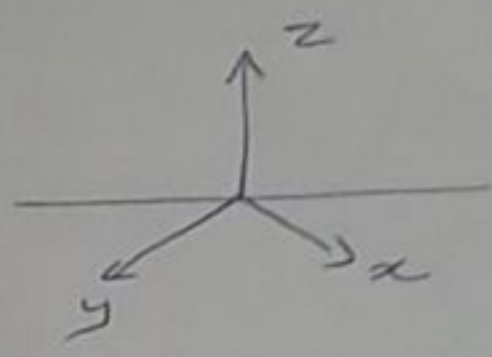
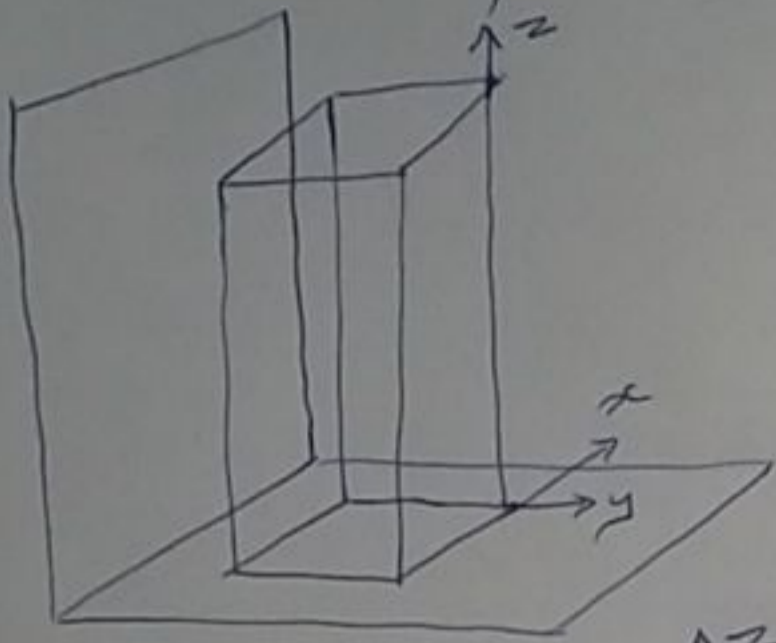

② When base on V.P (crosssection is seen in F.V)

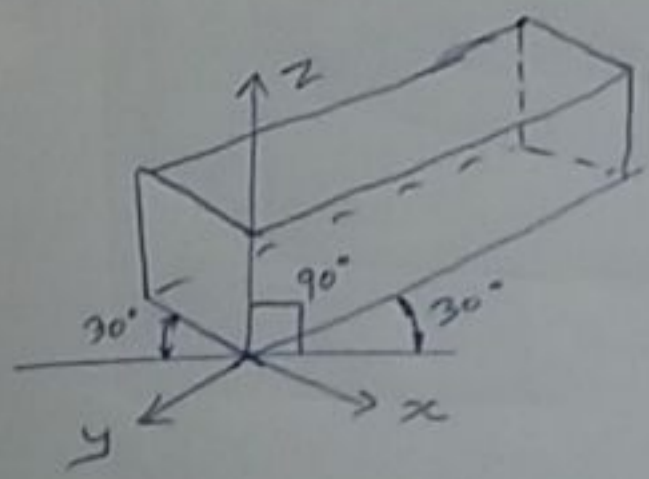
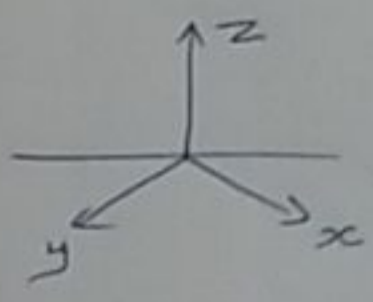
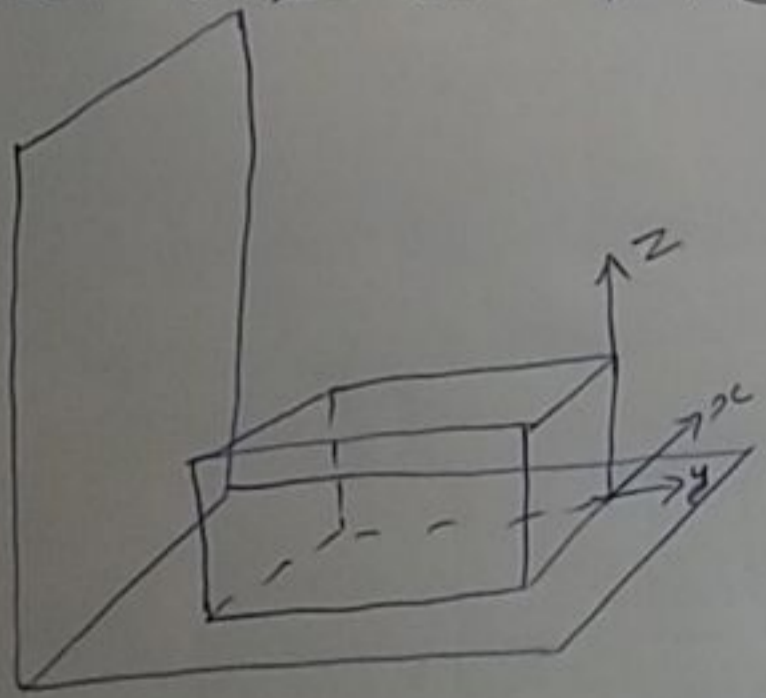

Draw the isometric View and Isometric Projection
of a pentagonal prism base 25mm & ht 50mm
resting on its base on H.P with one base edge
 \parallel to V.P.

Isometric View

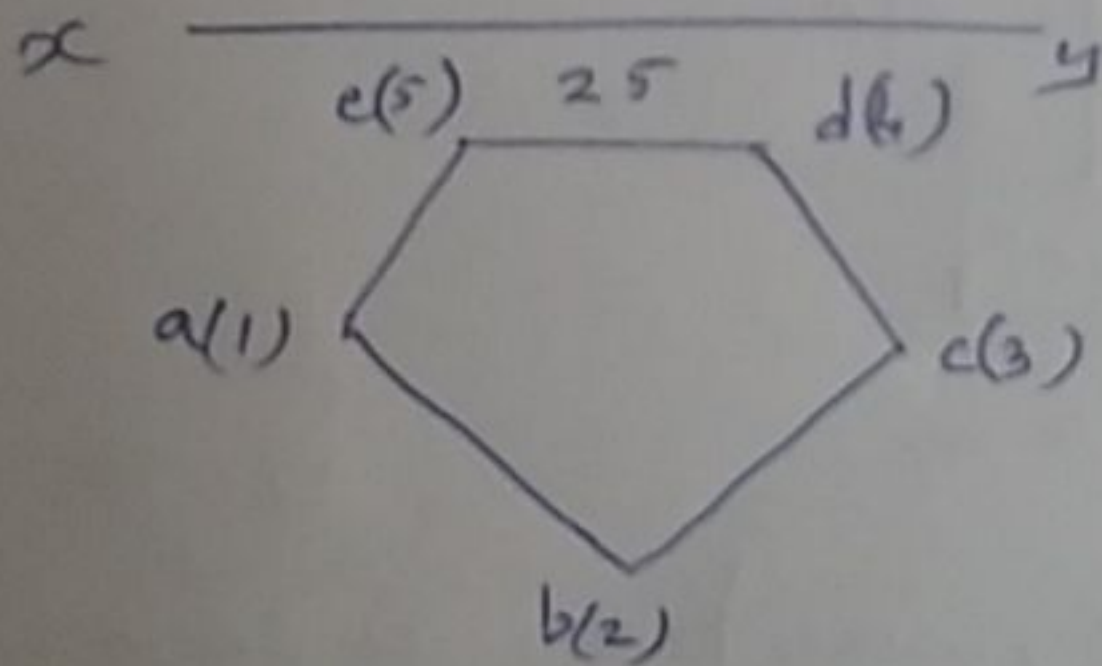

Isometric View

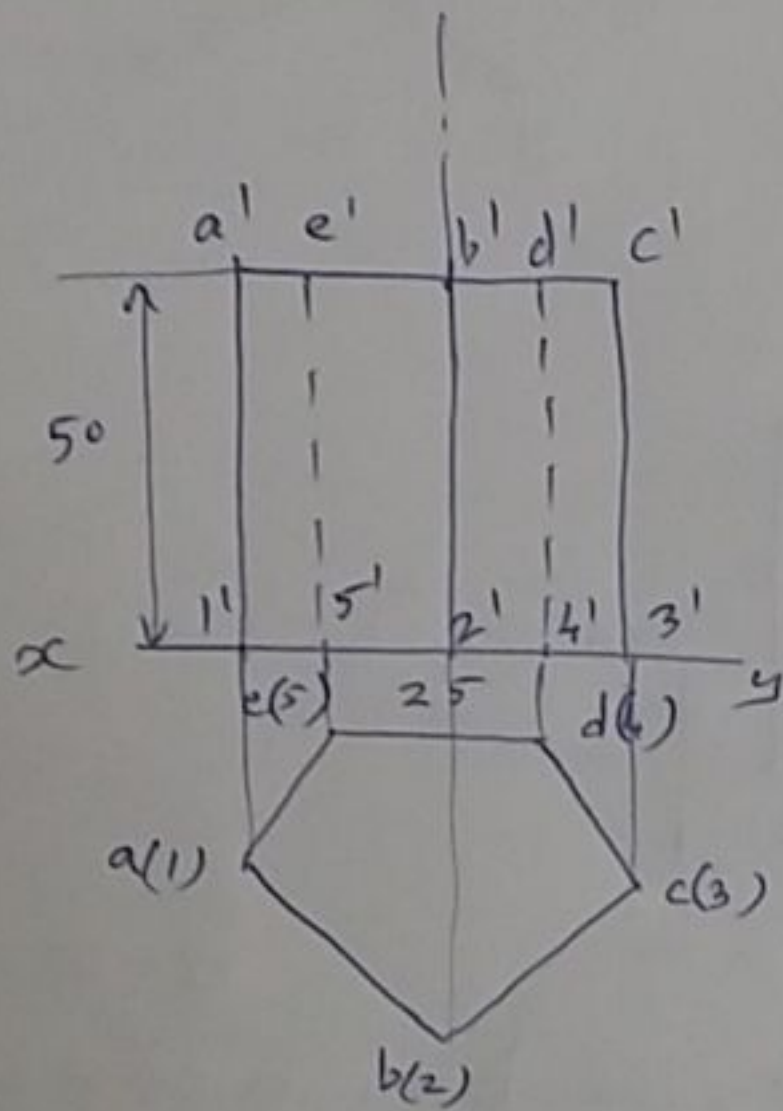

Isometric View

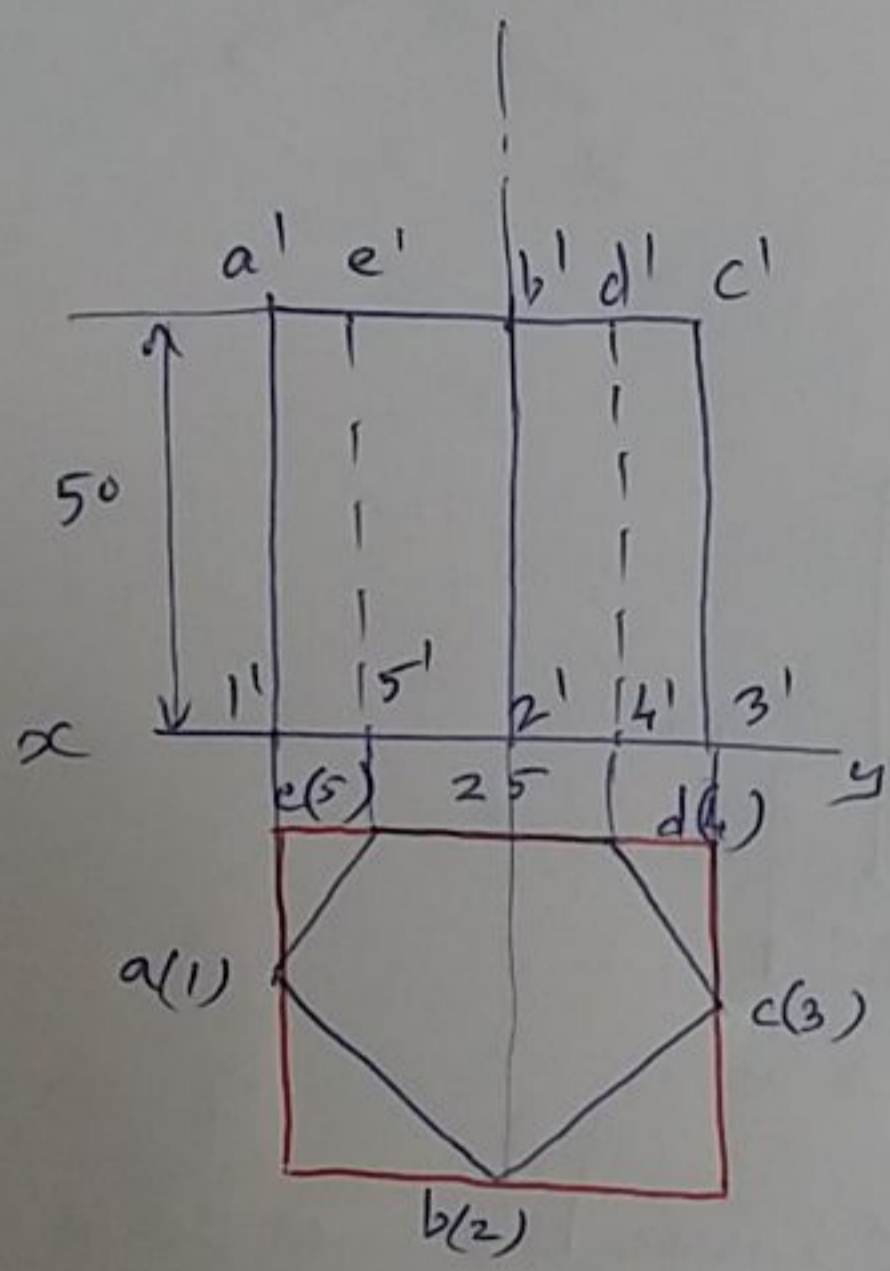

Isometric View

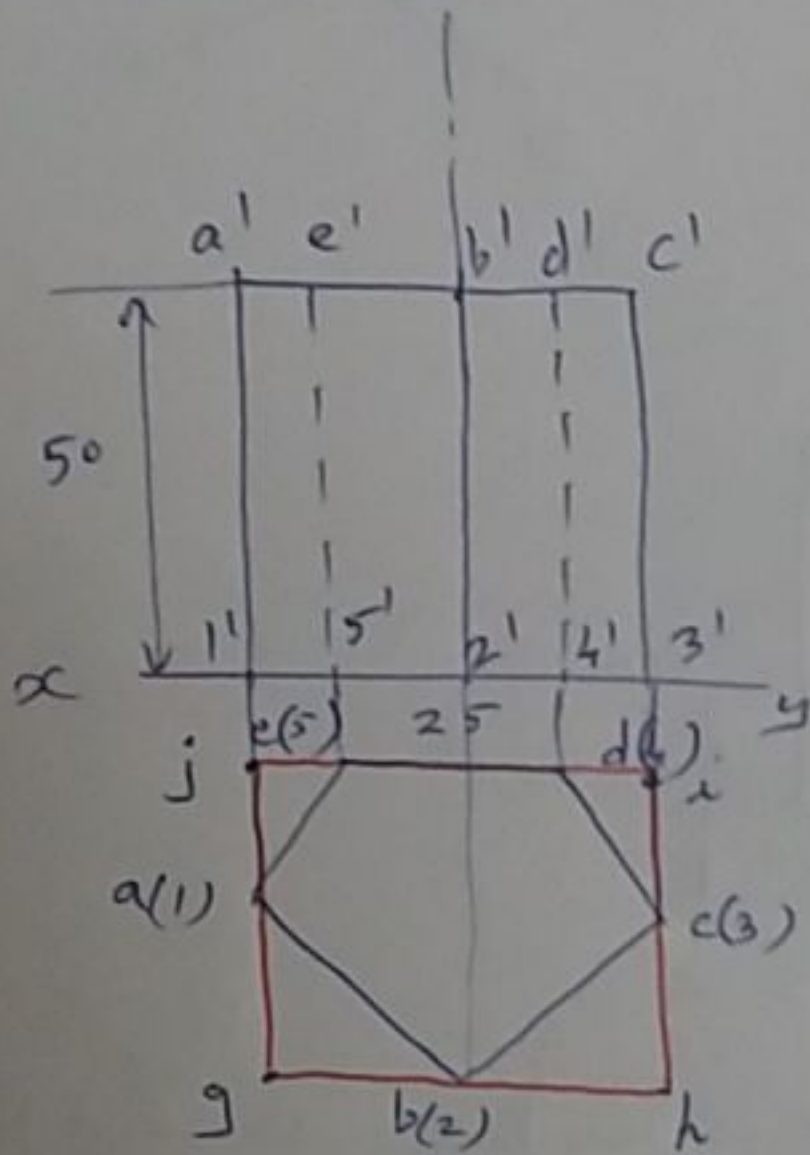

Isometric View

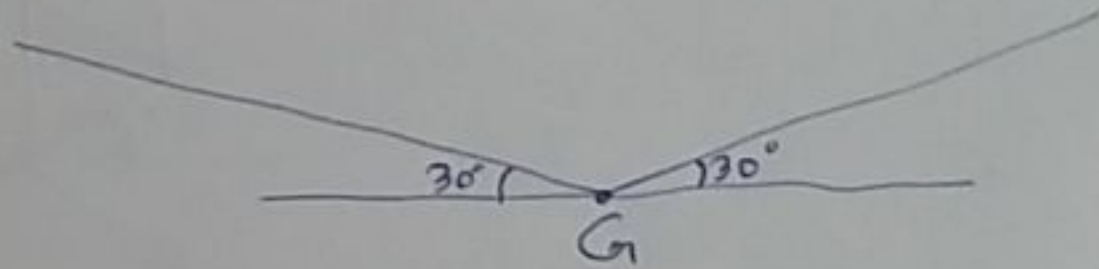
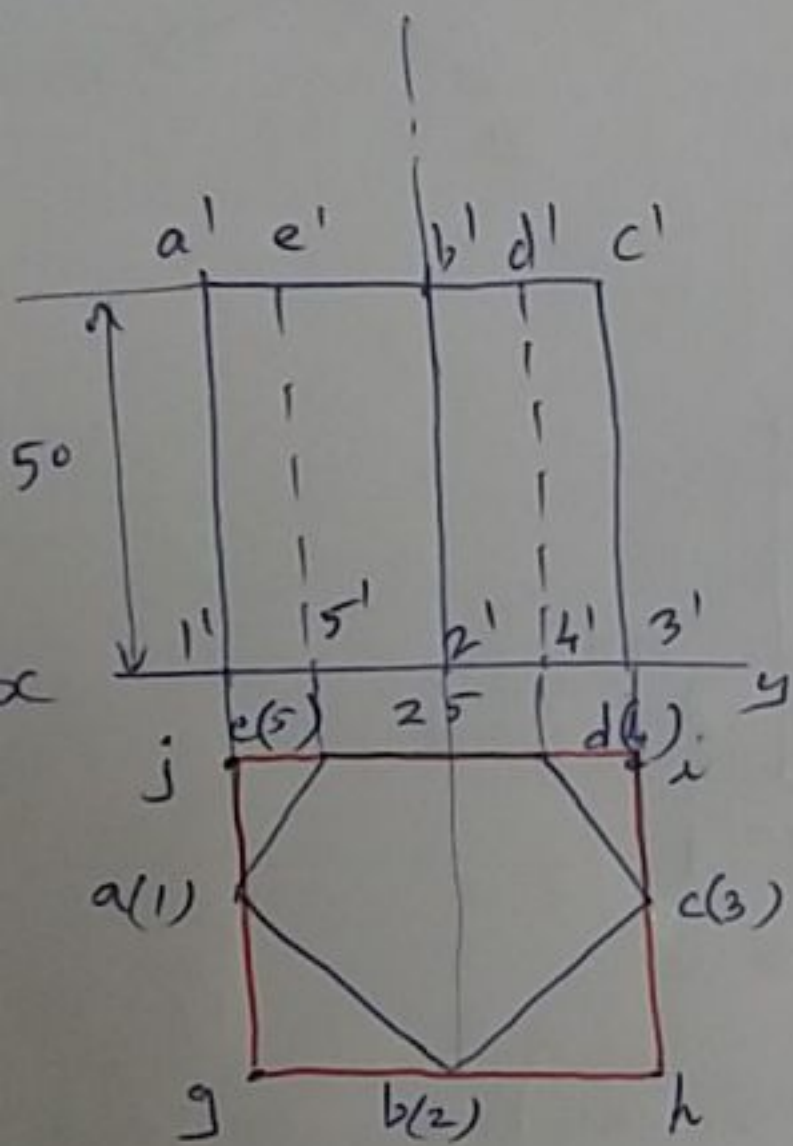

Isometric View

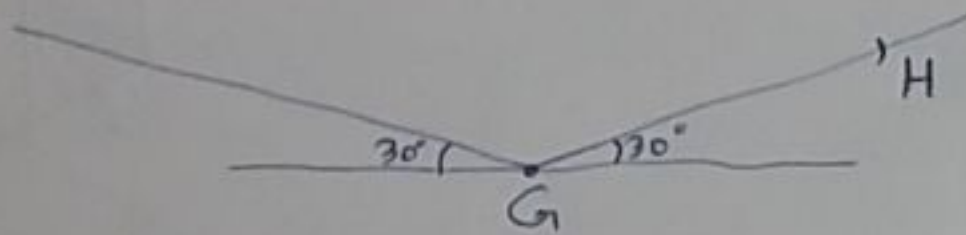
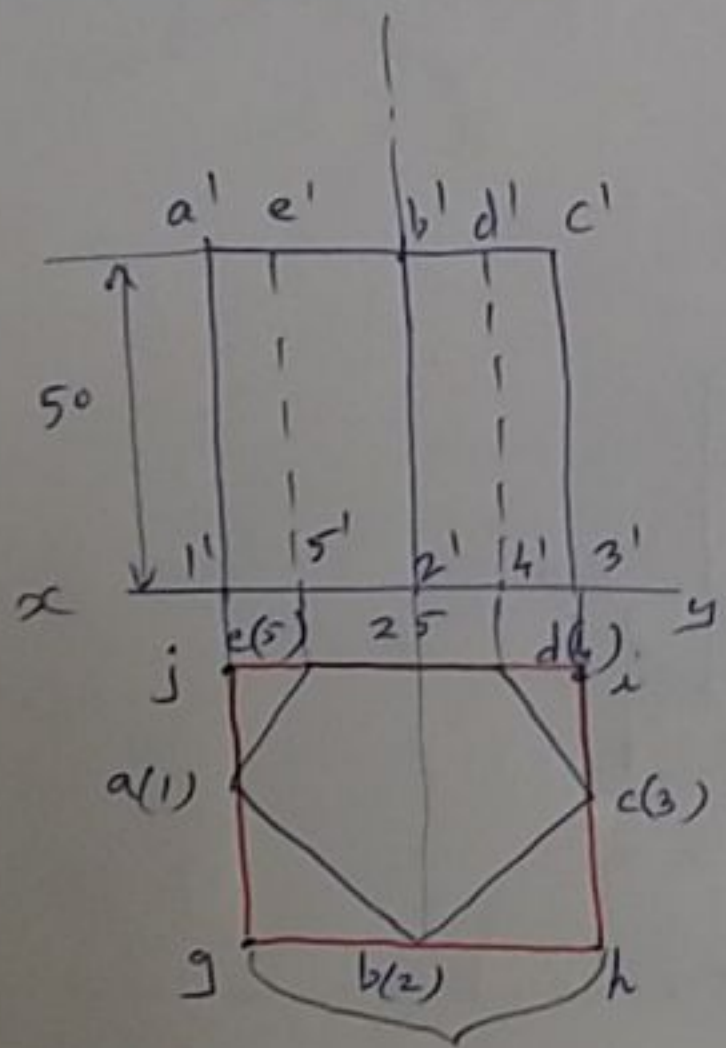

Isometric View

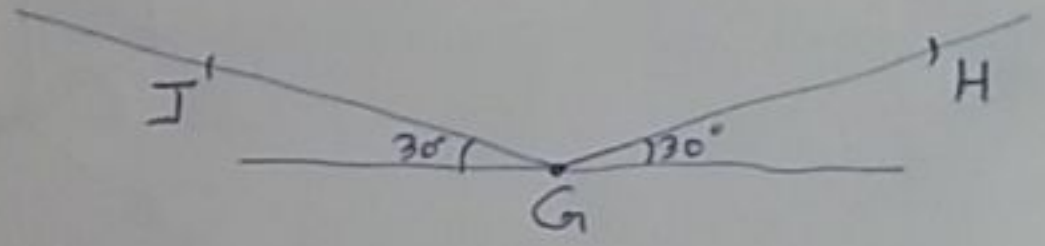
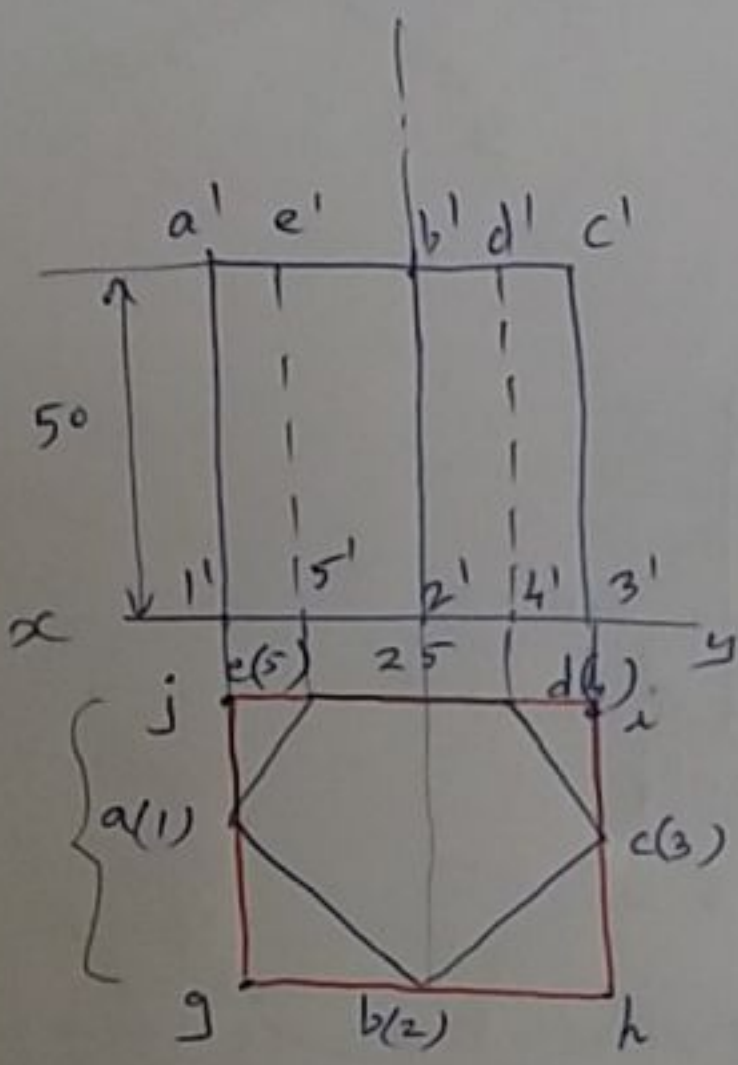

Isometric View

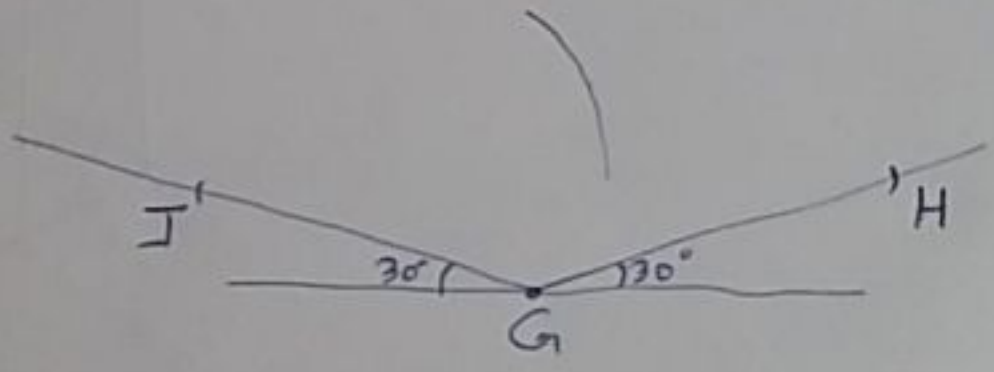
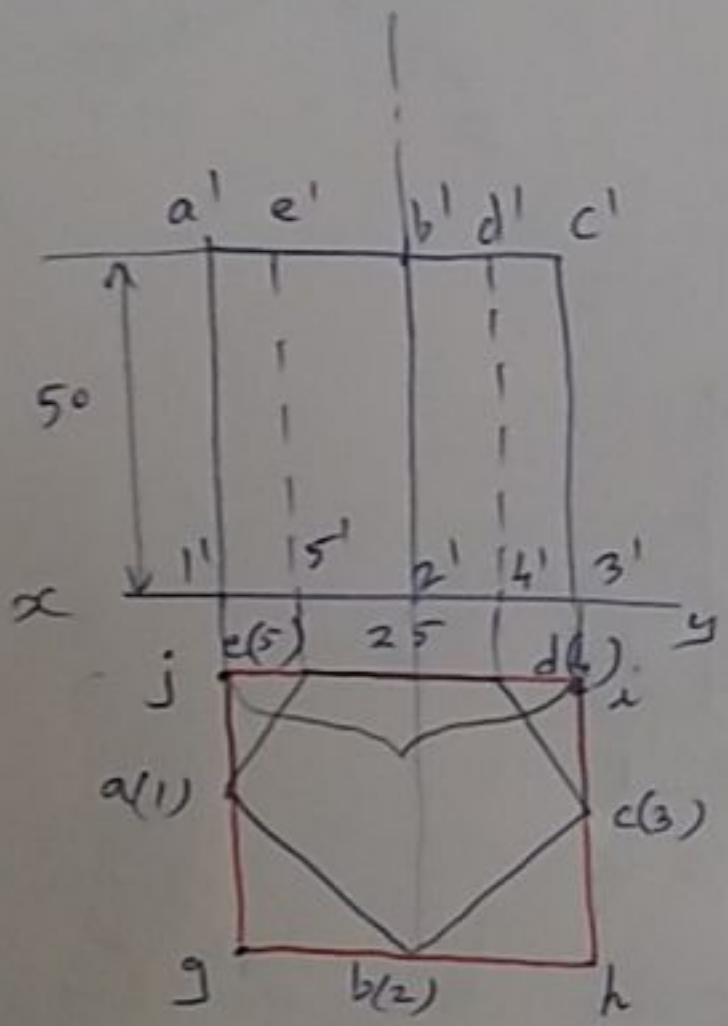

Isometric View

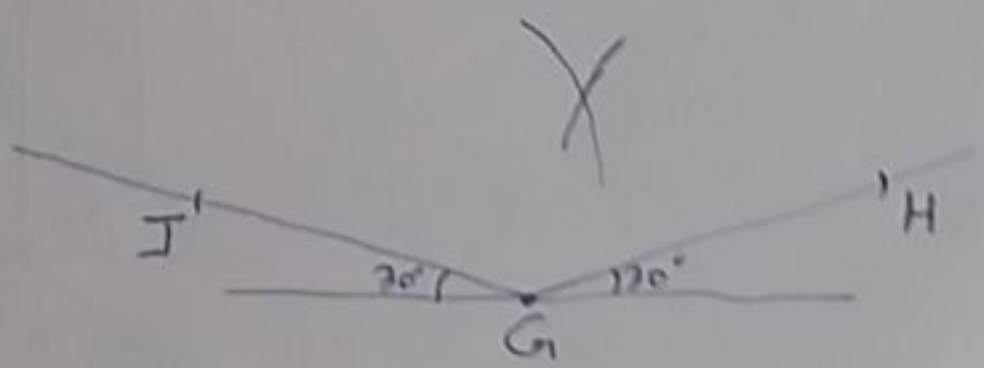
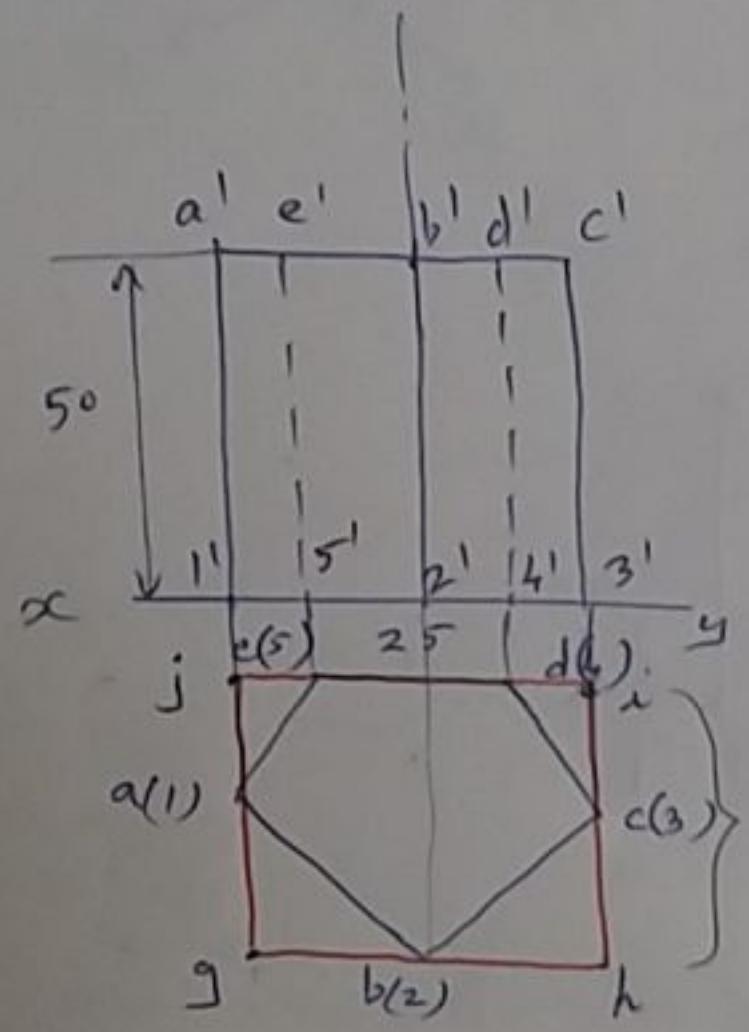

Isometric View

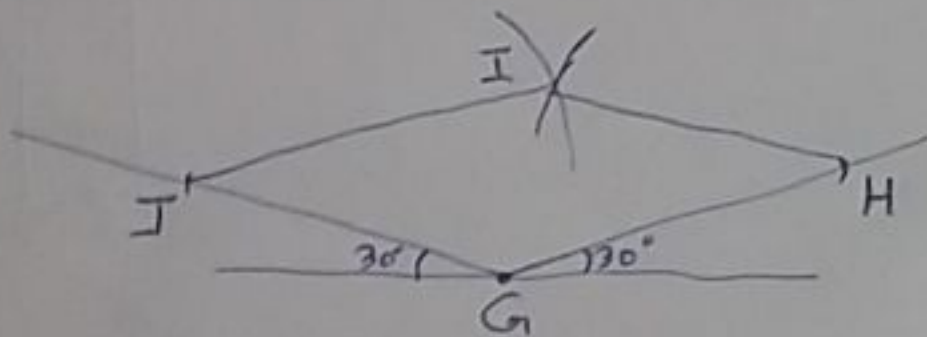
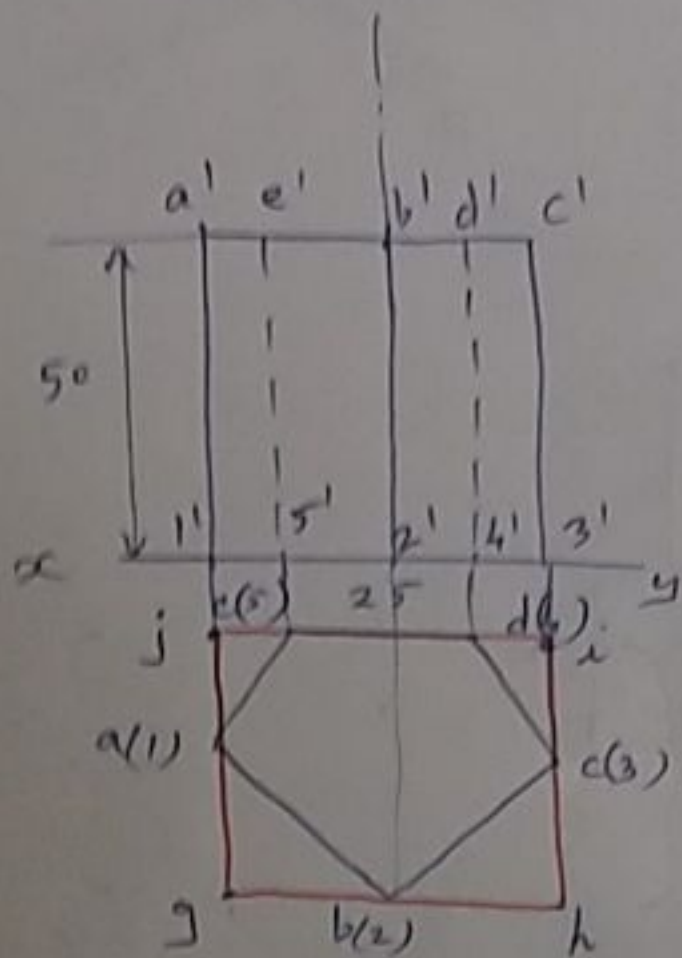

Isometric View

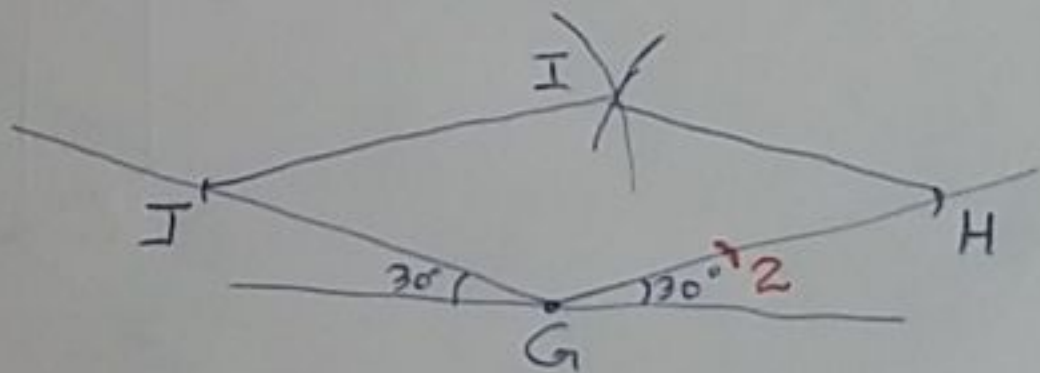
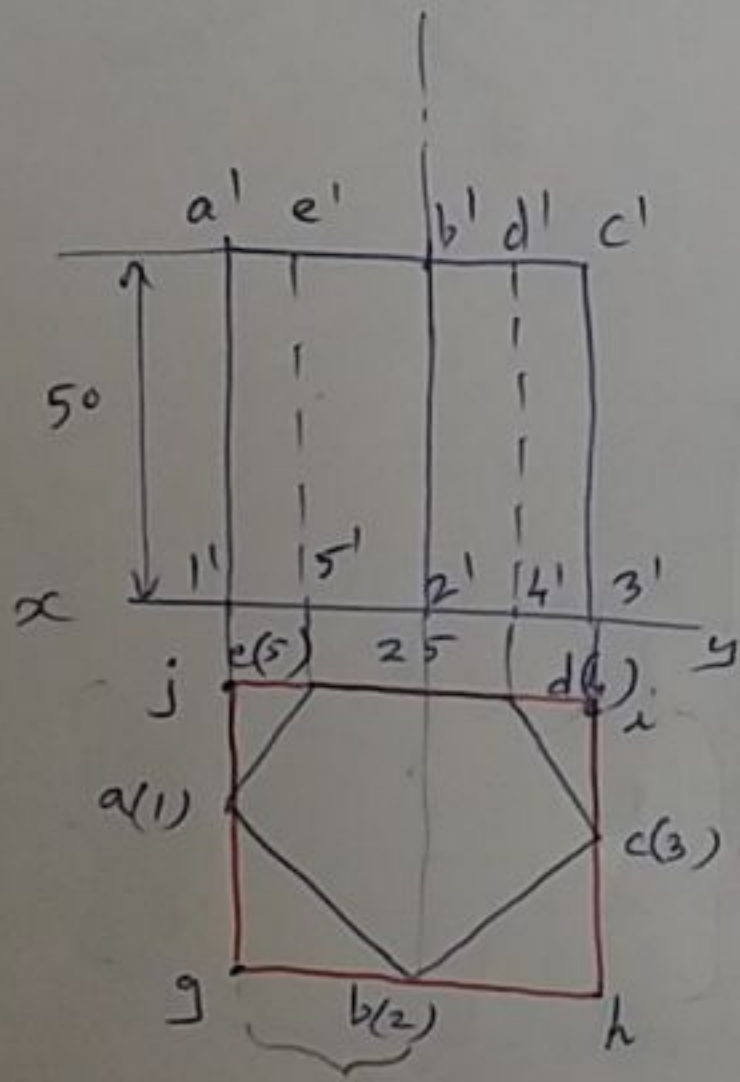

Isometric View

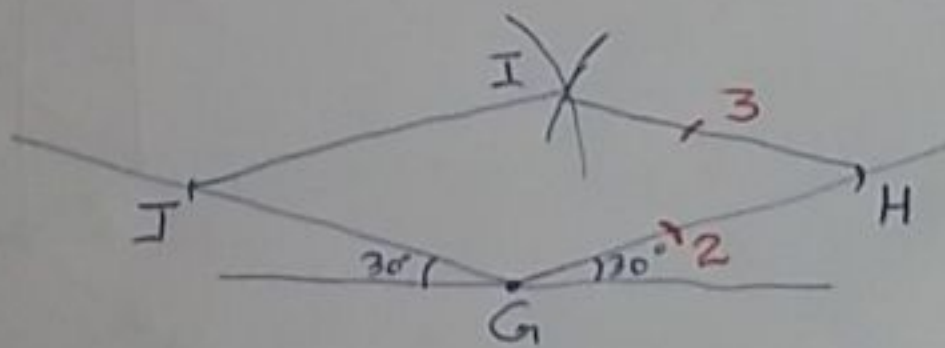
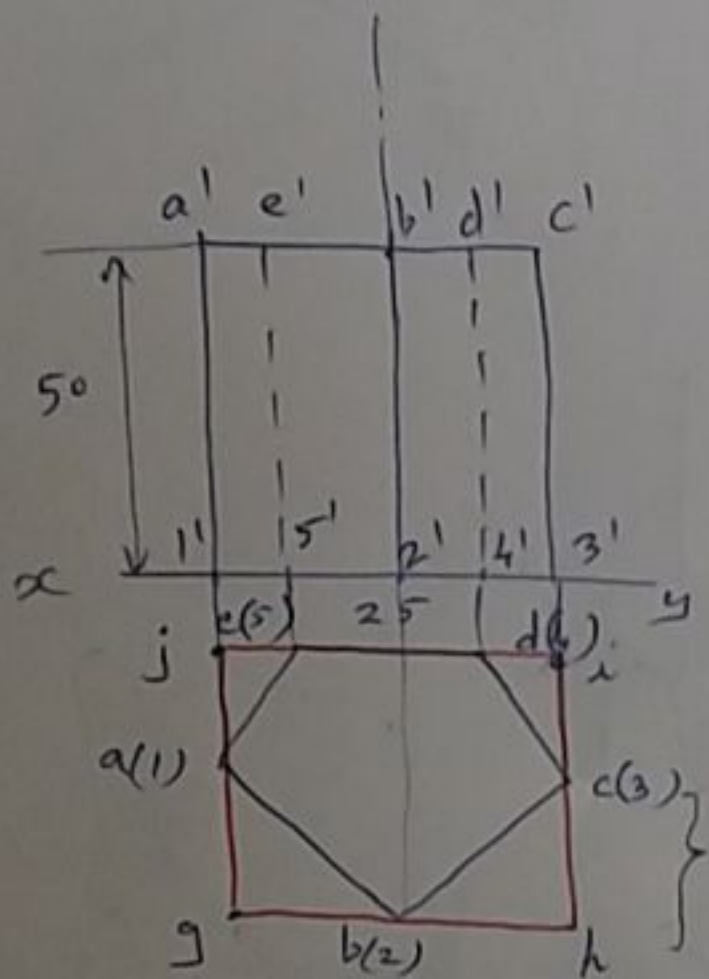

Isometric View

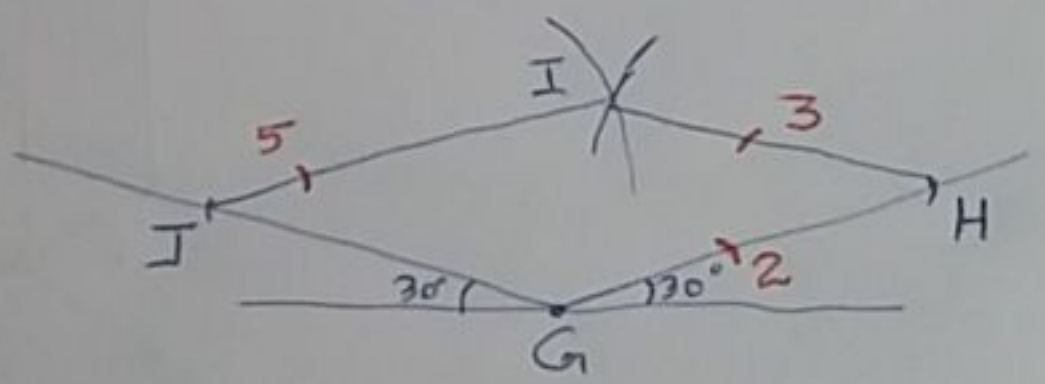
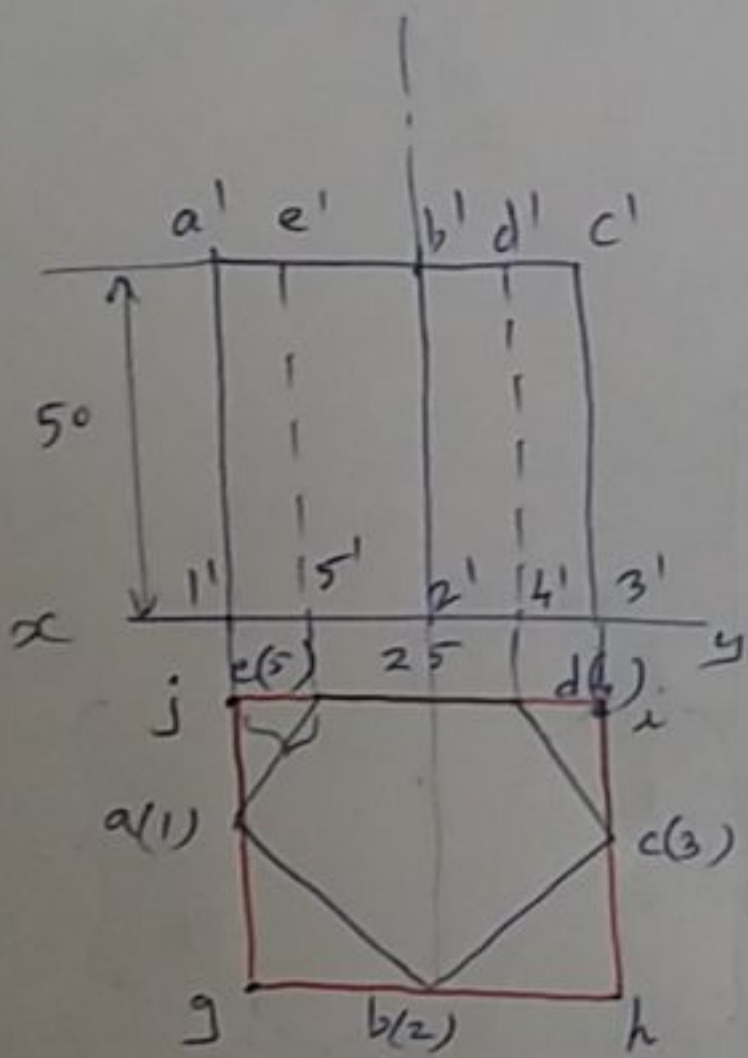

Isometric View

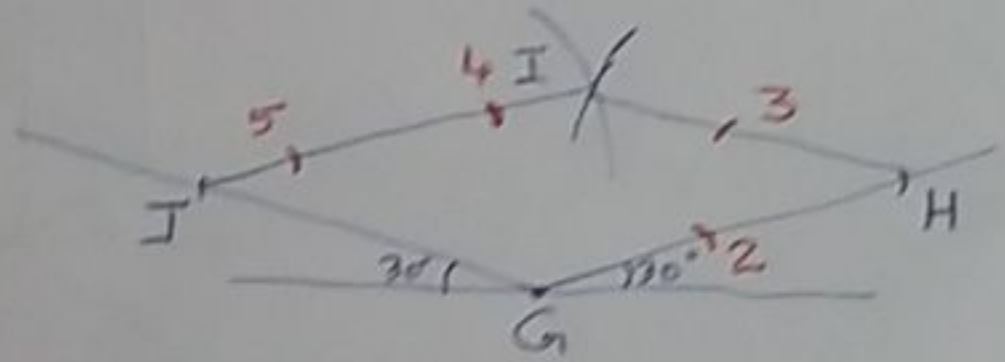
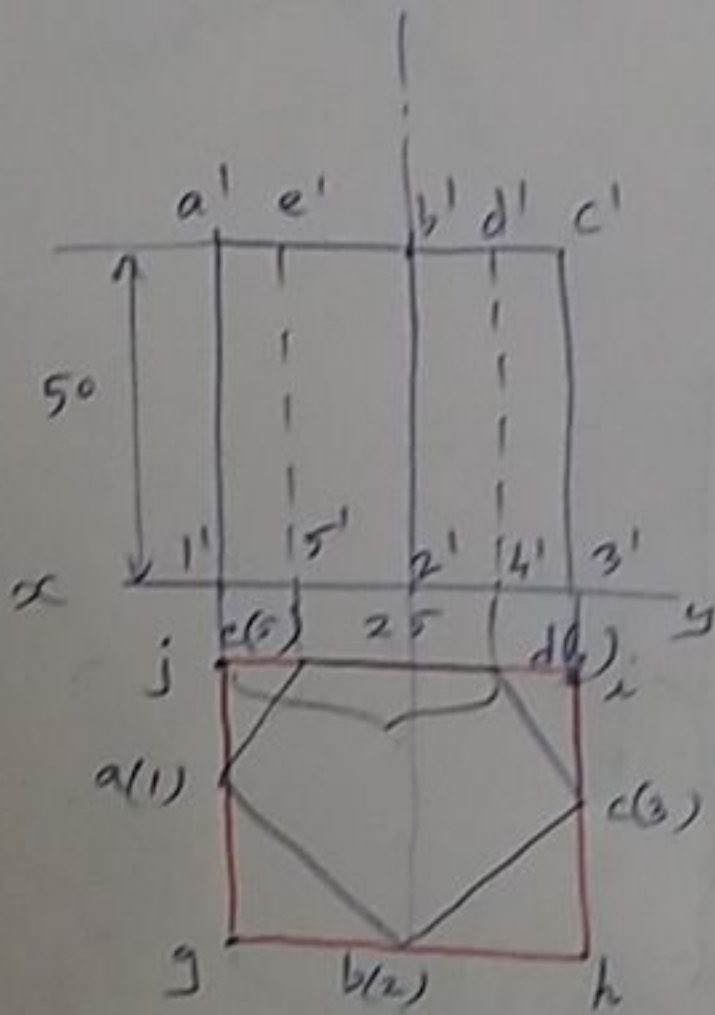

Isometric View

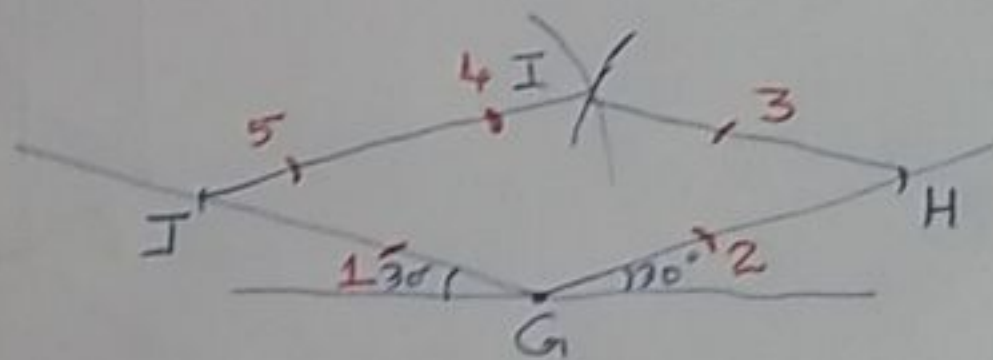
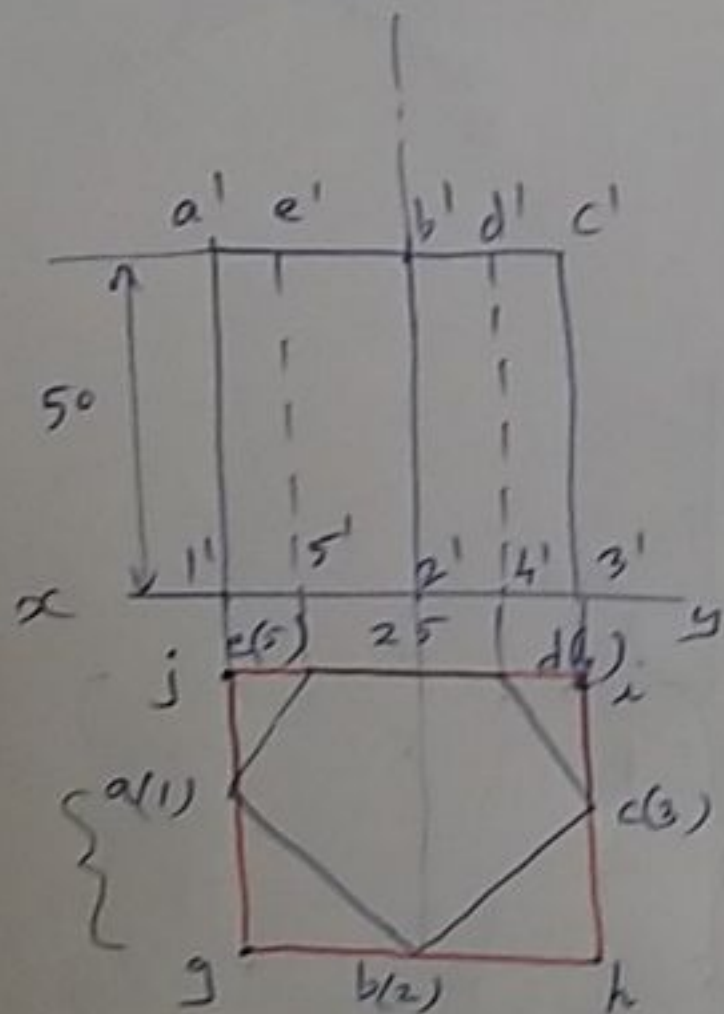

Isometric View

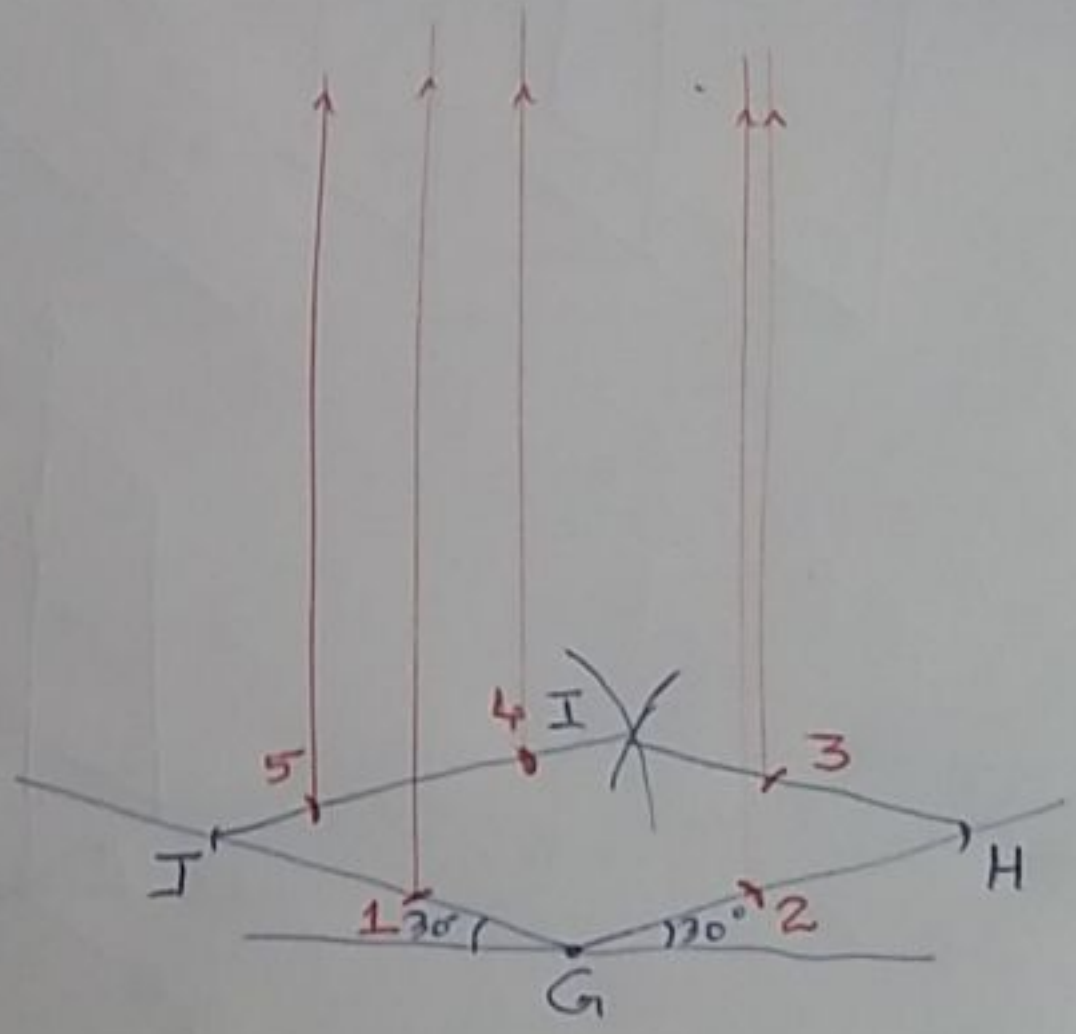
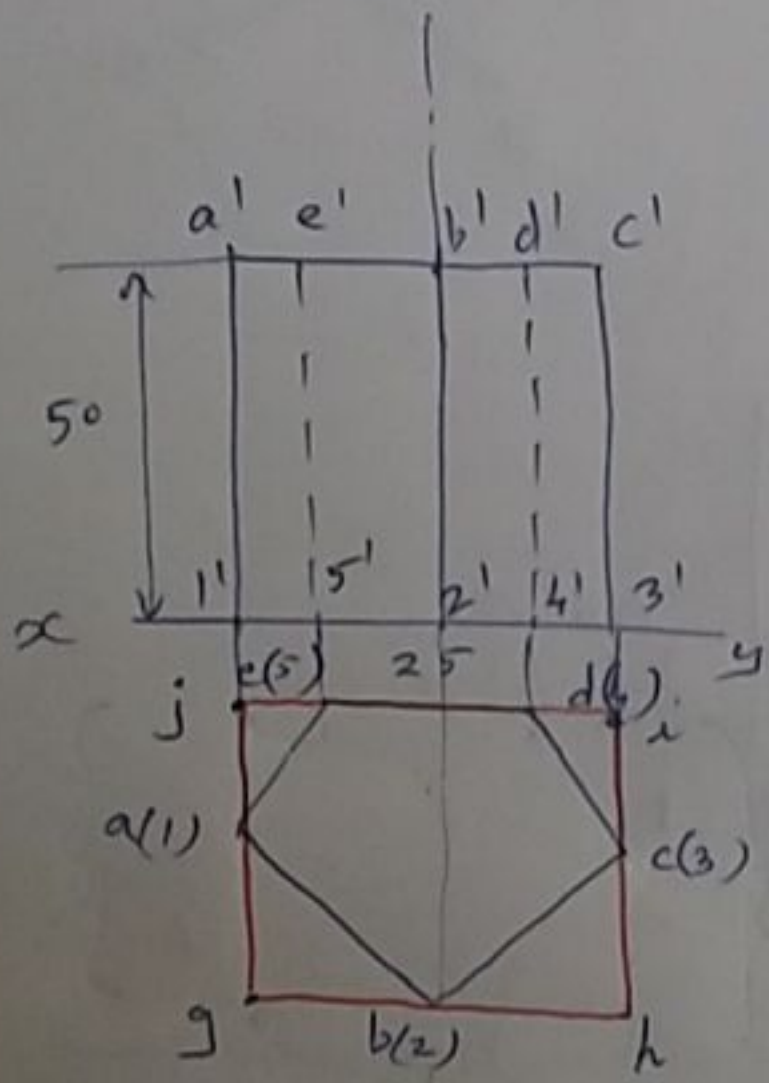

Isometric View

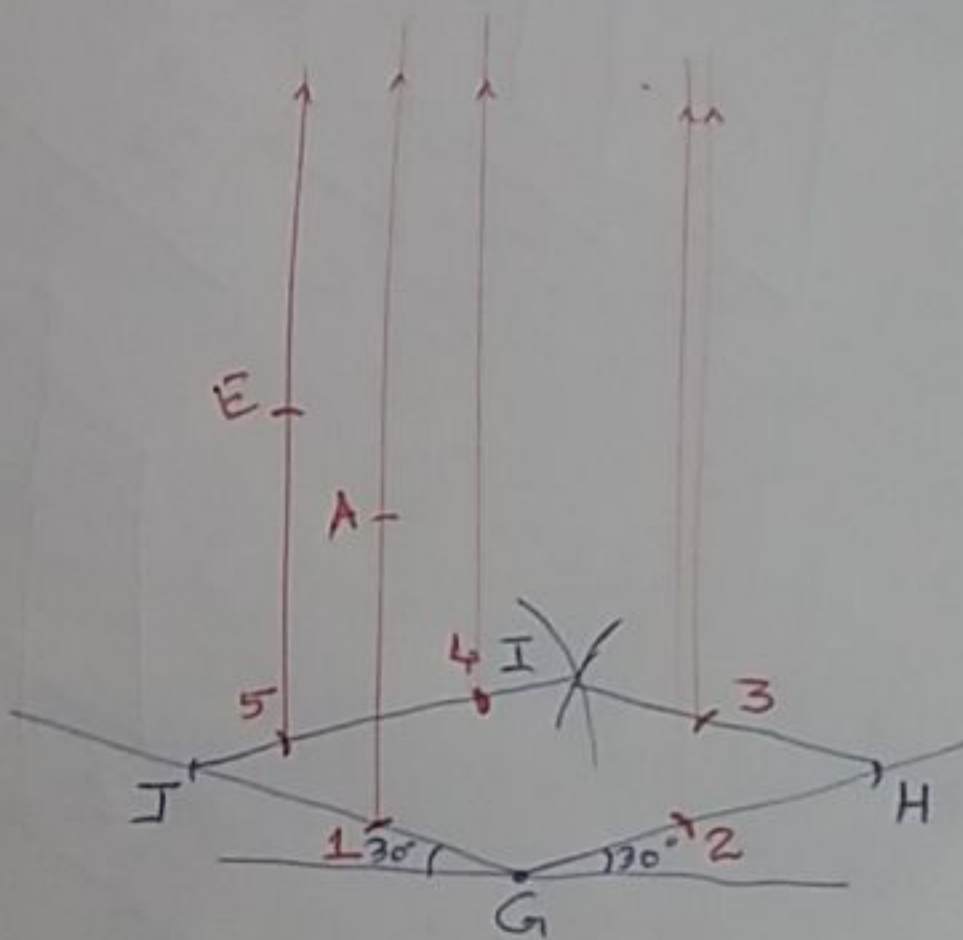
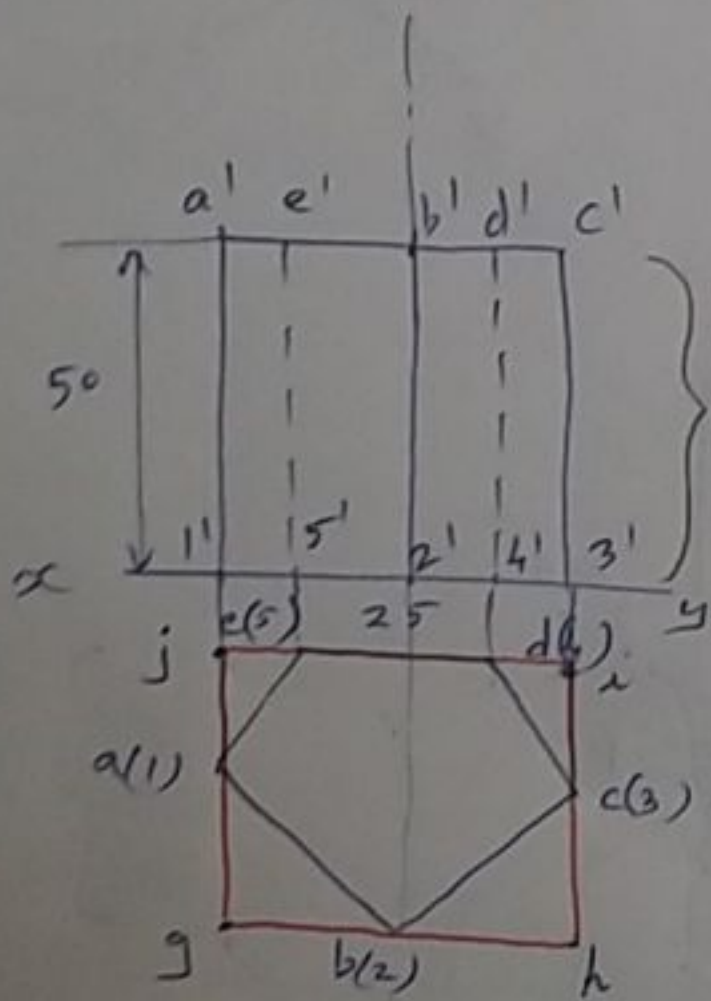

Isometric View

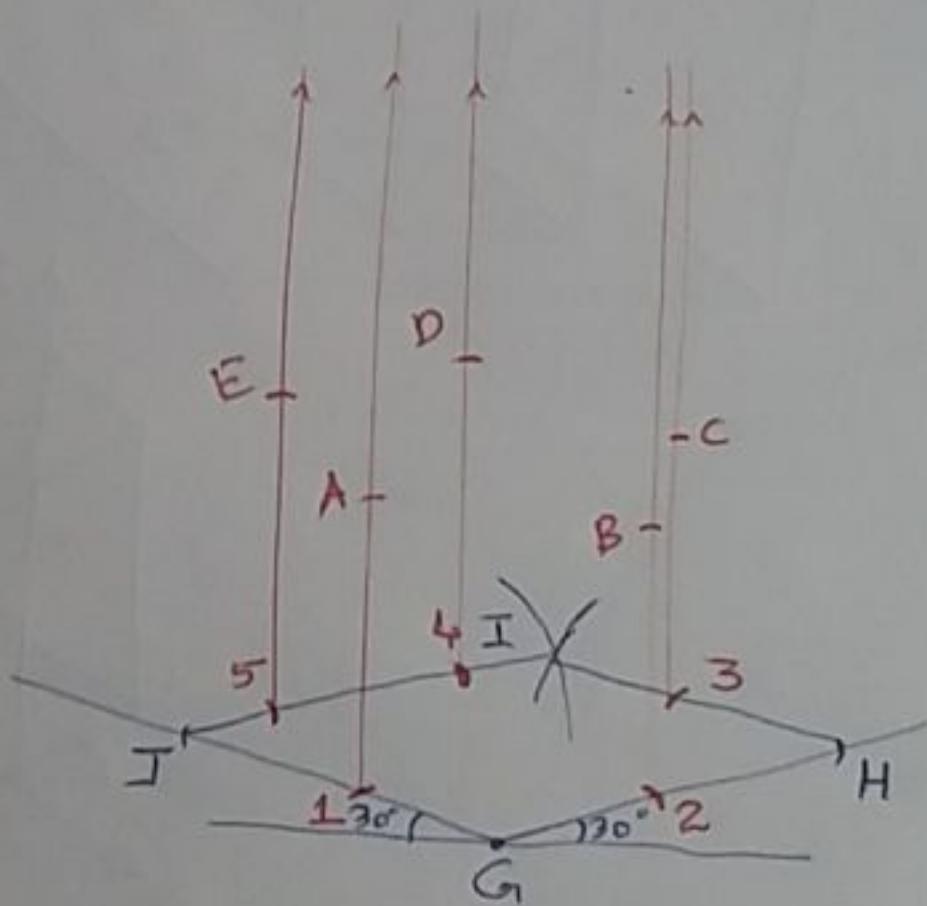
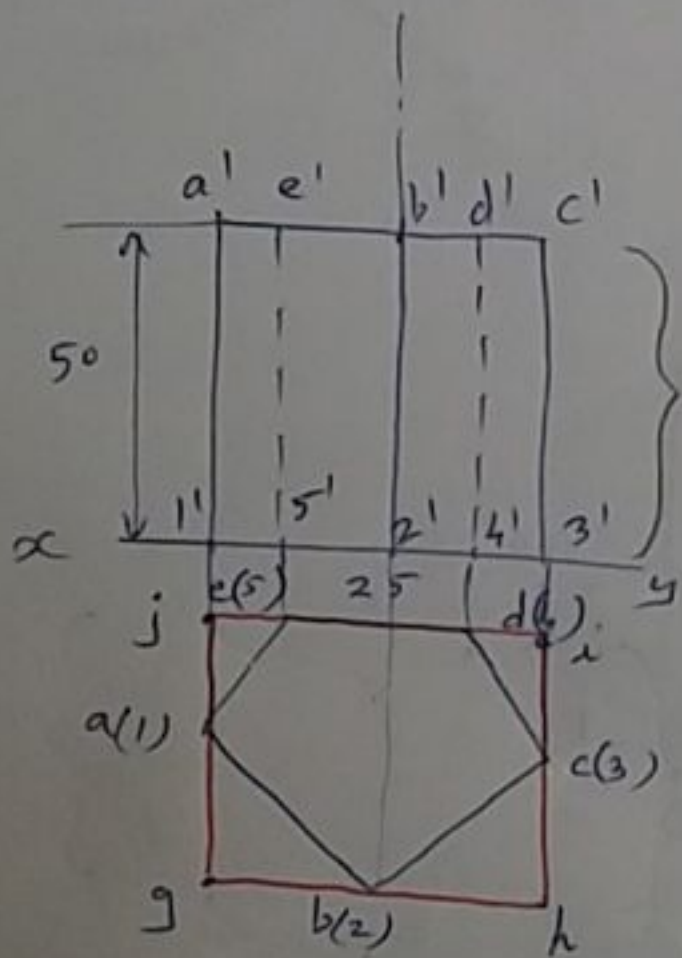

Isometric View

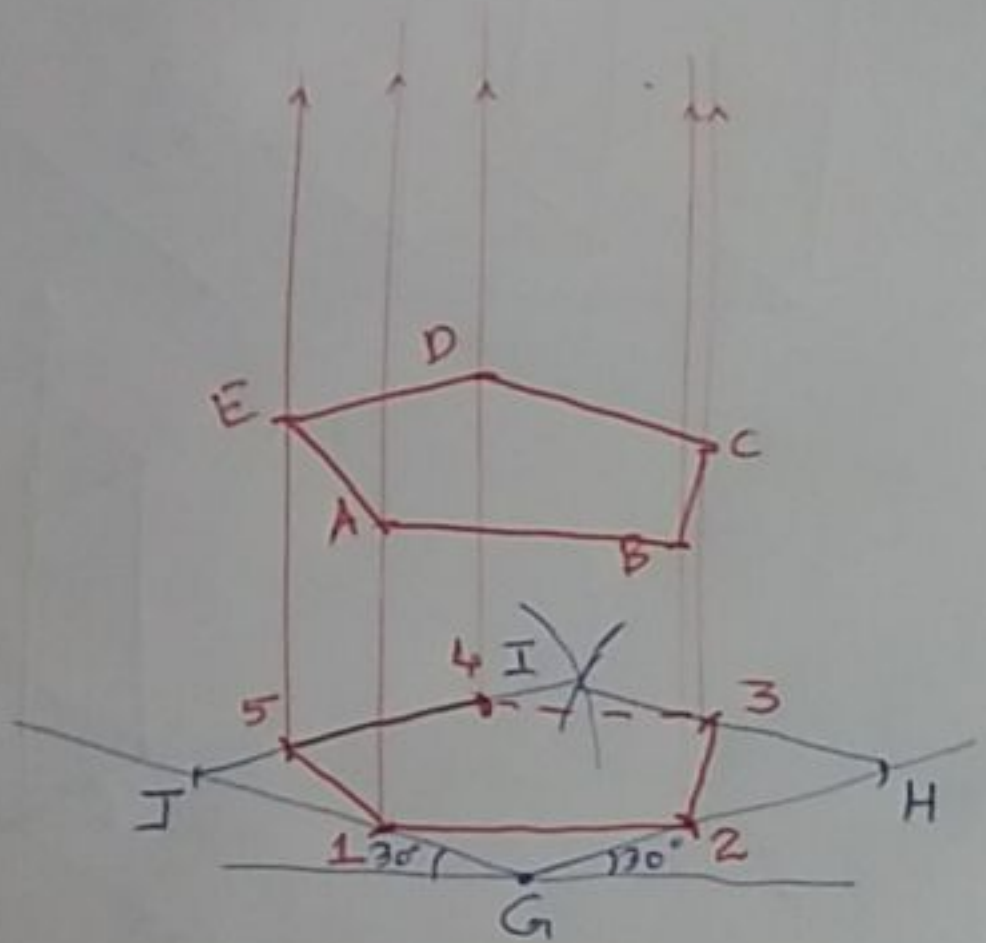
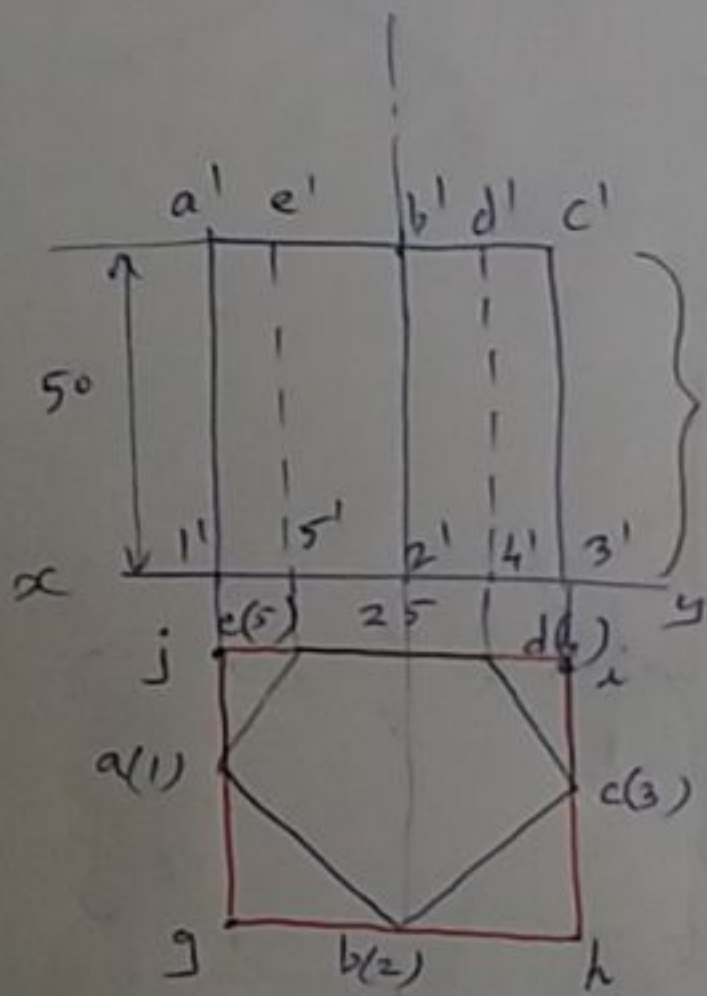

Isometric View

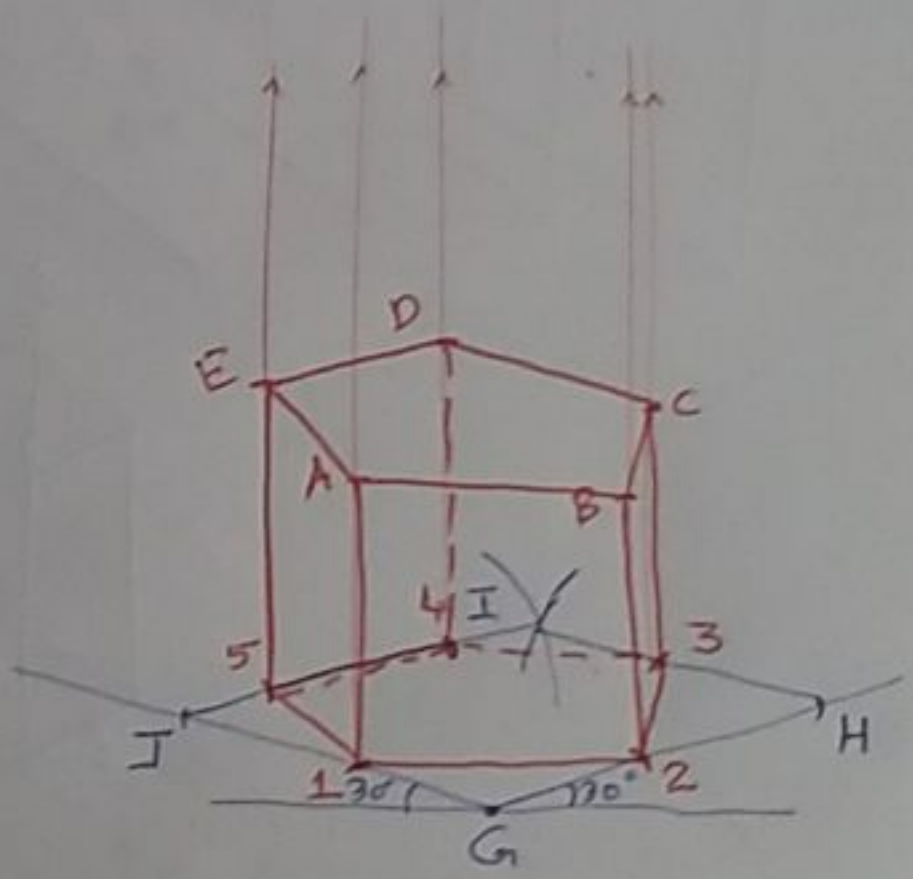
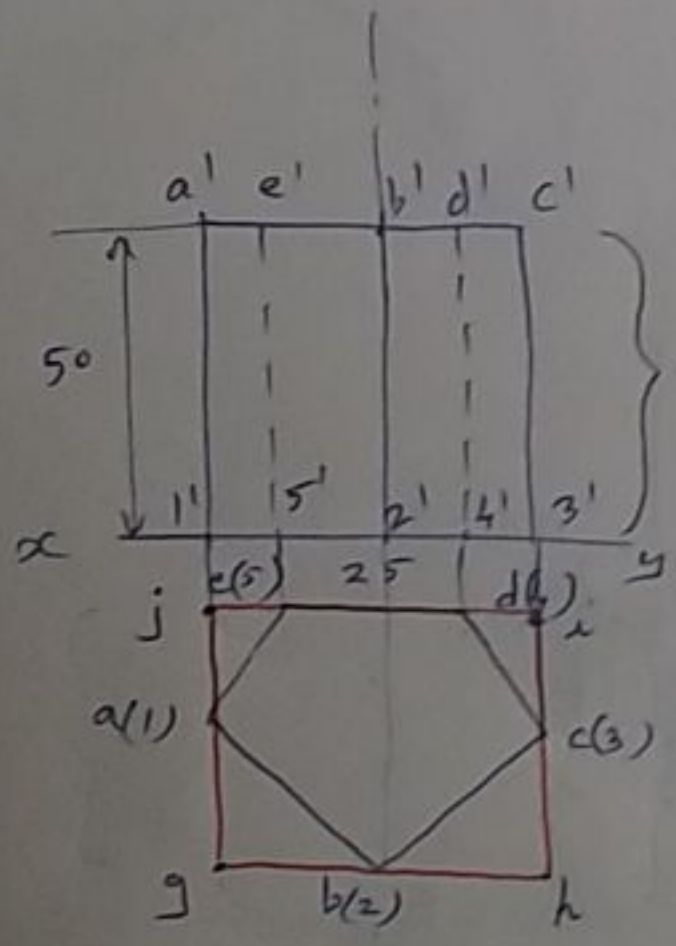

Isometric View

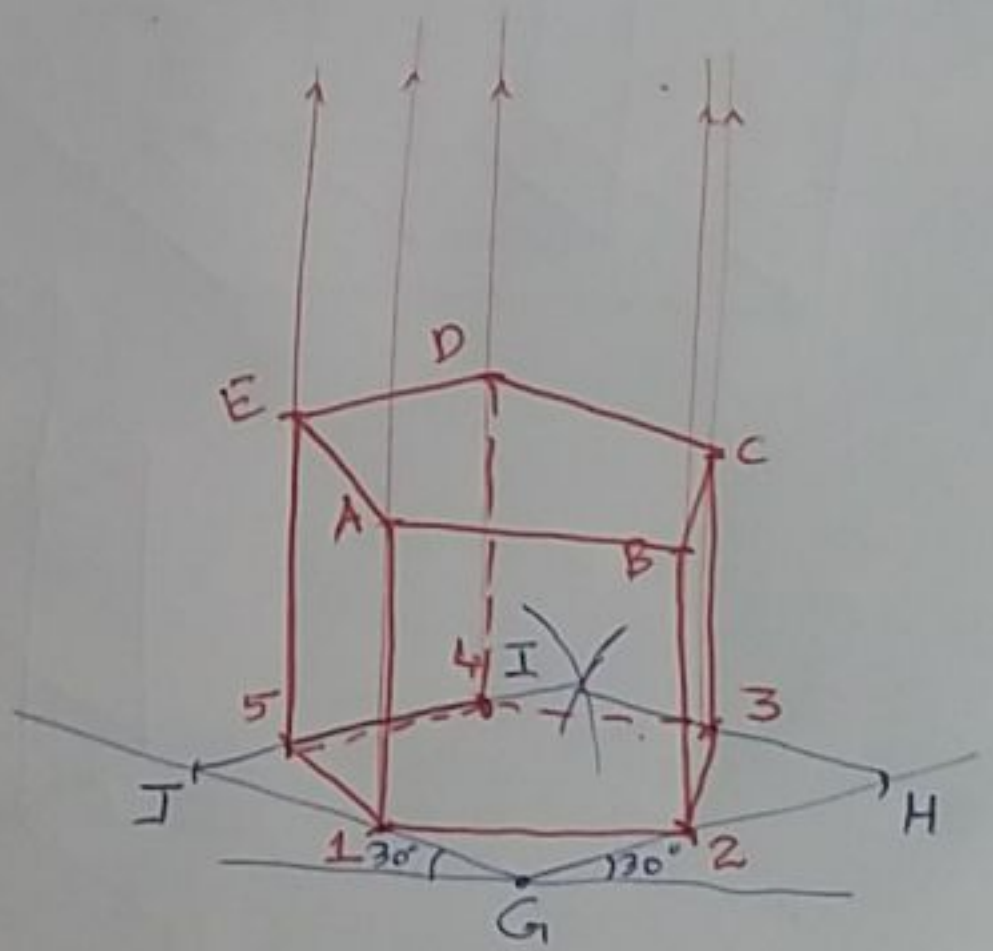
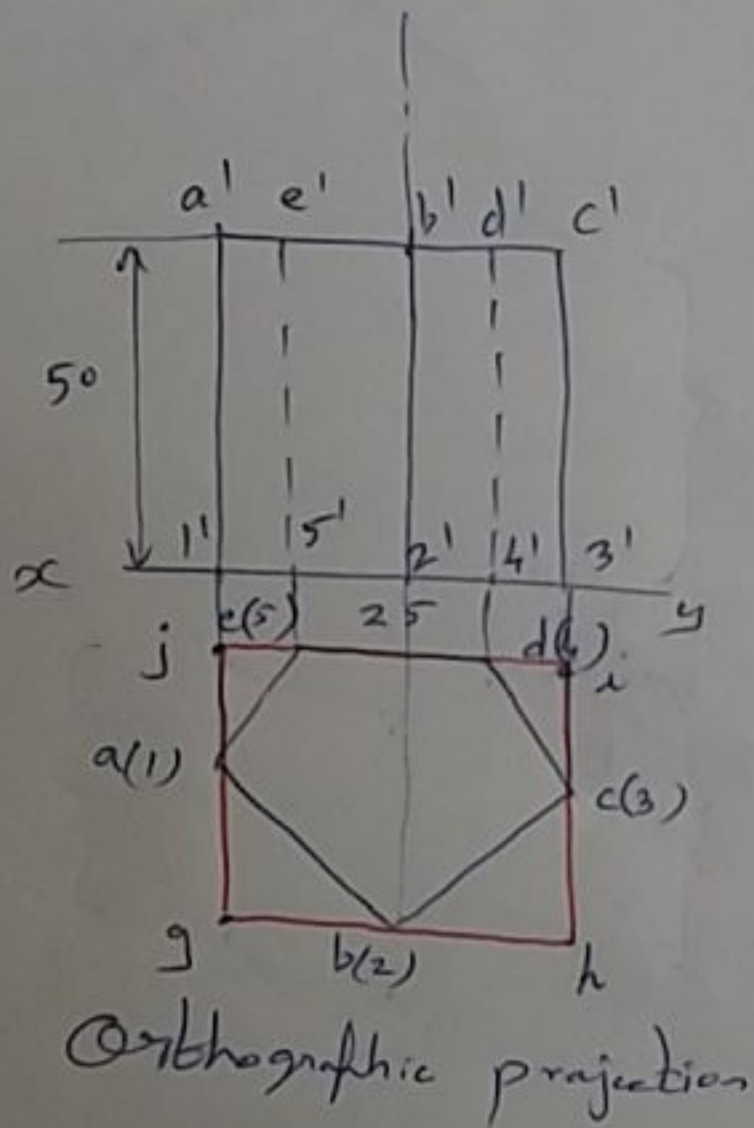

Isometric View

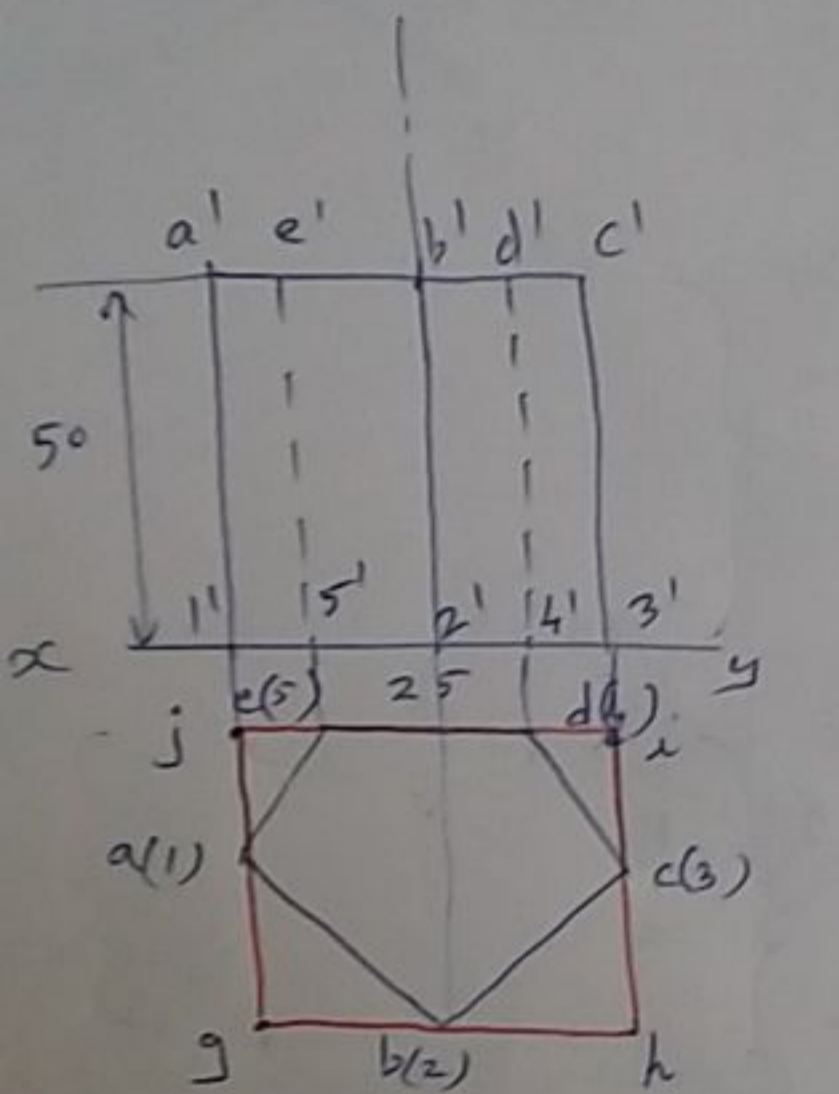

Orthographic projection

Isometric projection

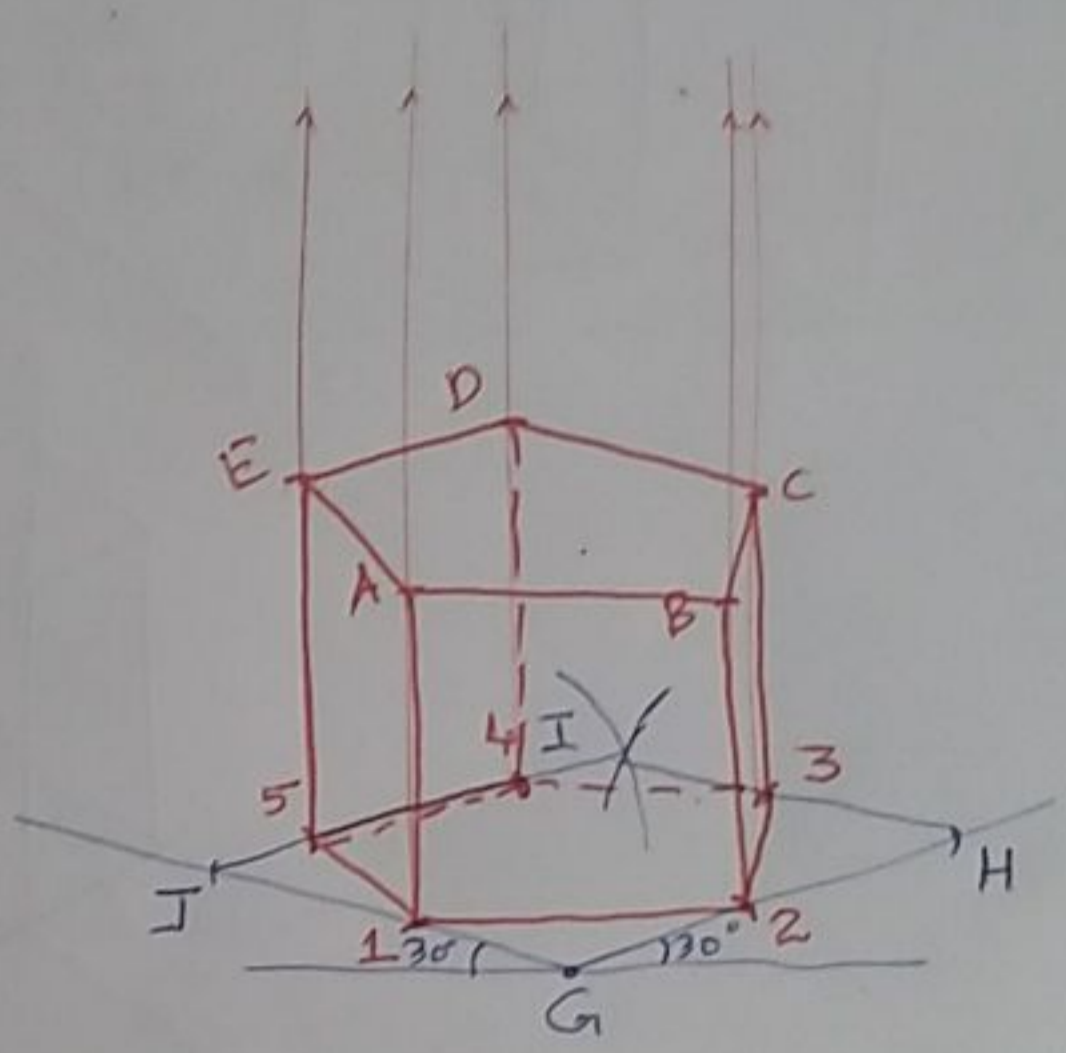

Isometric View

Isometric Scale

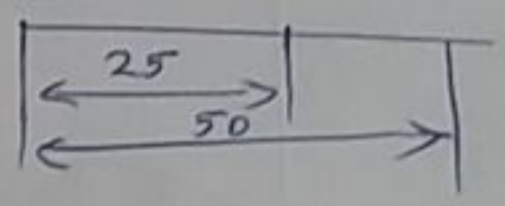

isometric projection

Isometric Scale

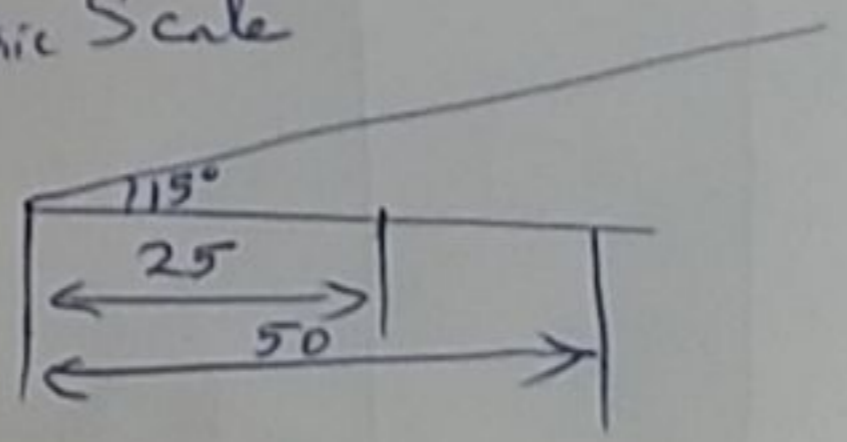

Isometric Scale

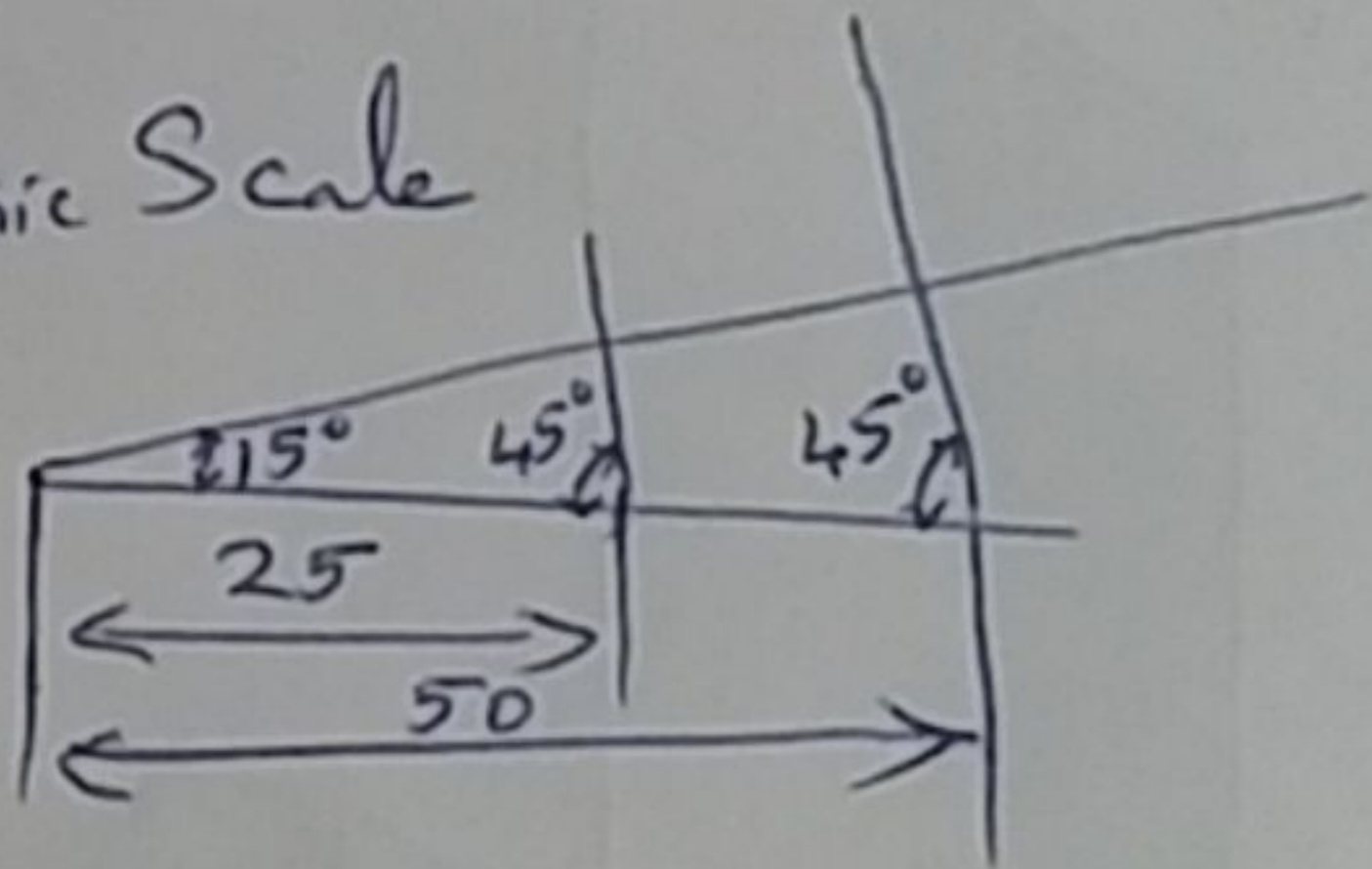

Isometric Scale

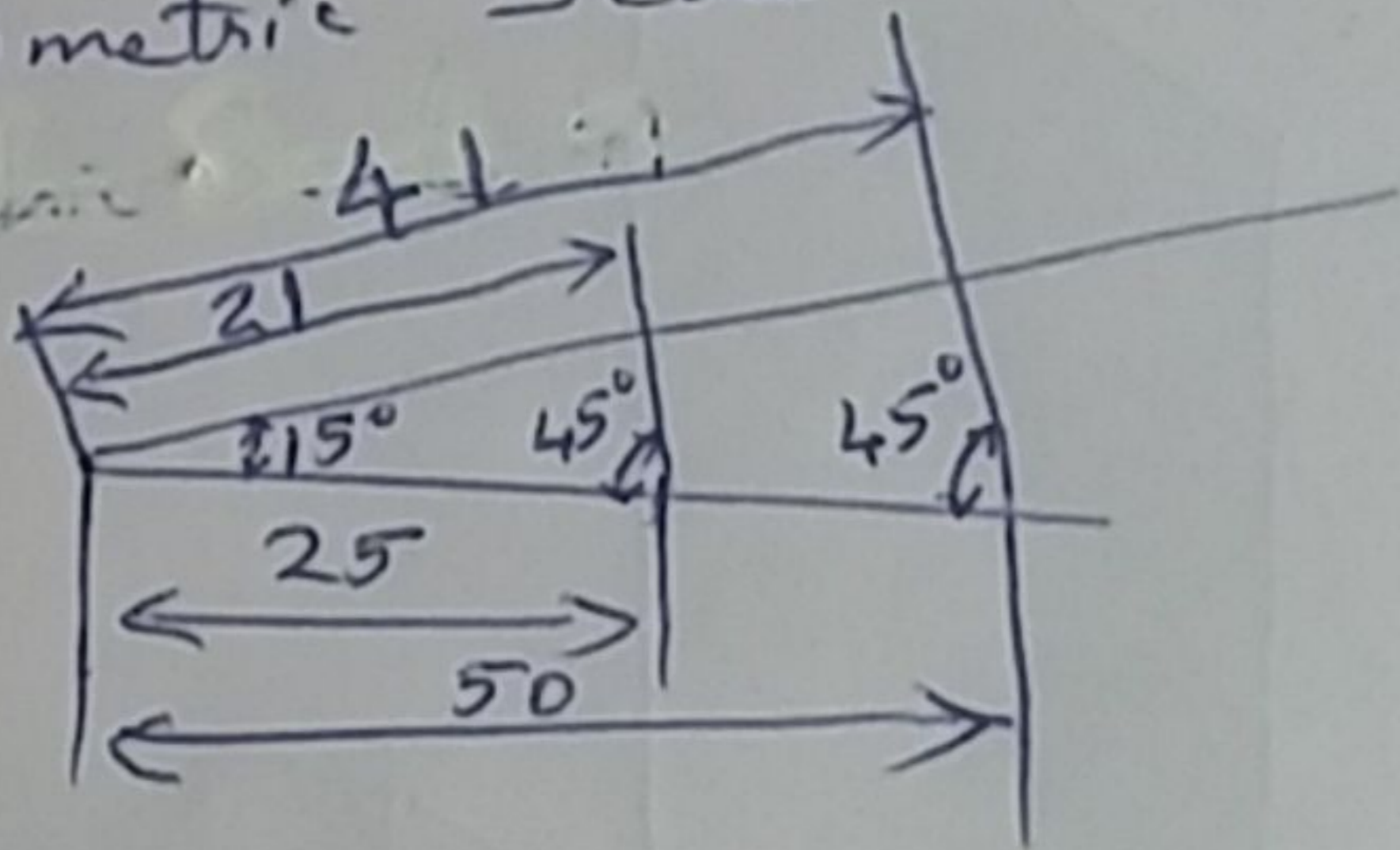

Isometric projection

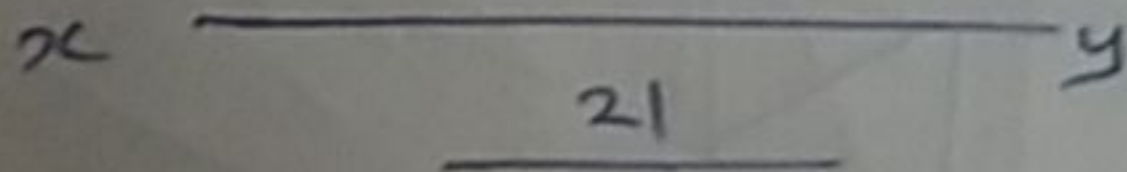

Isometric projection

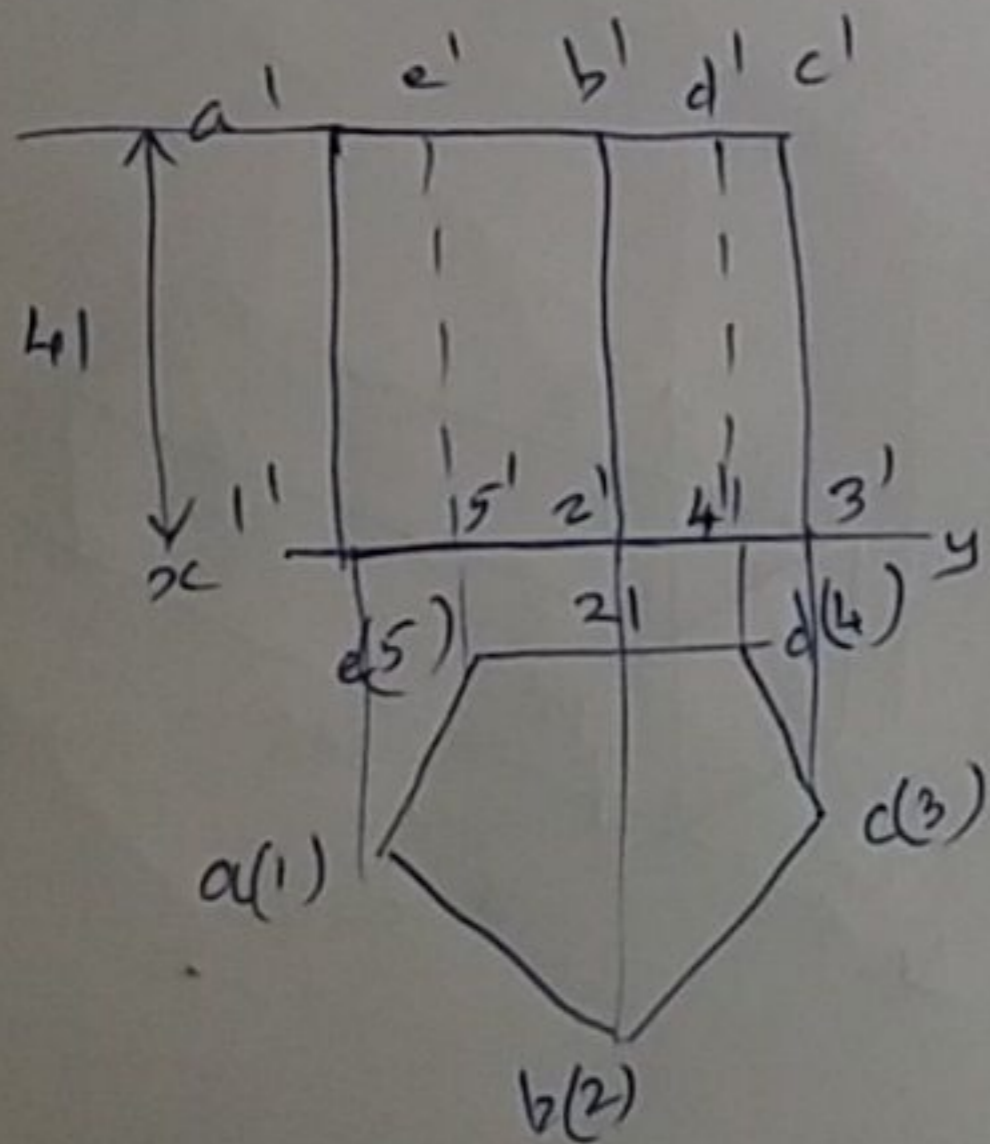

Isometric Scale

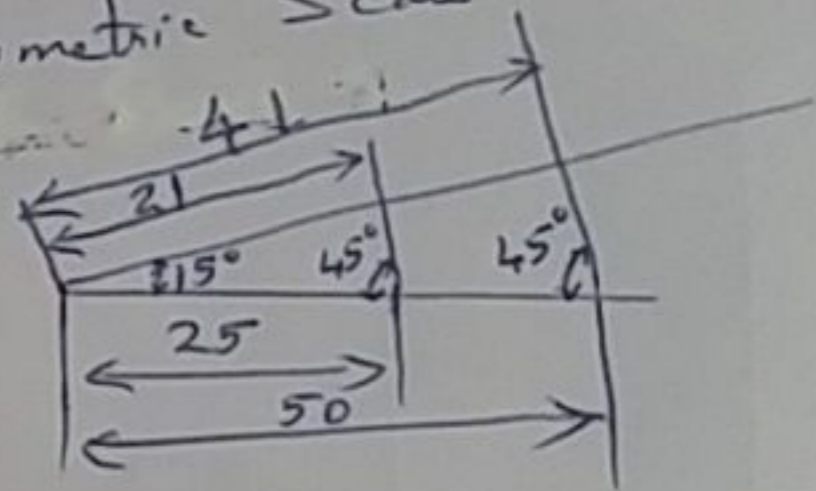

Isometric projection

Isometric

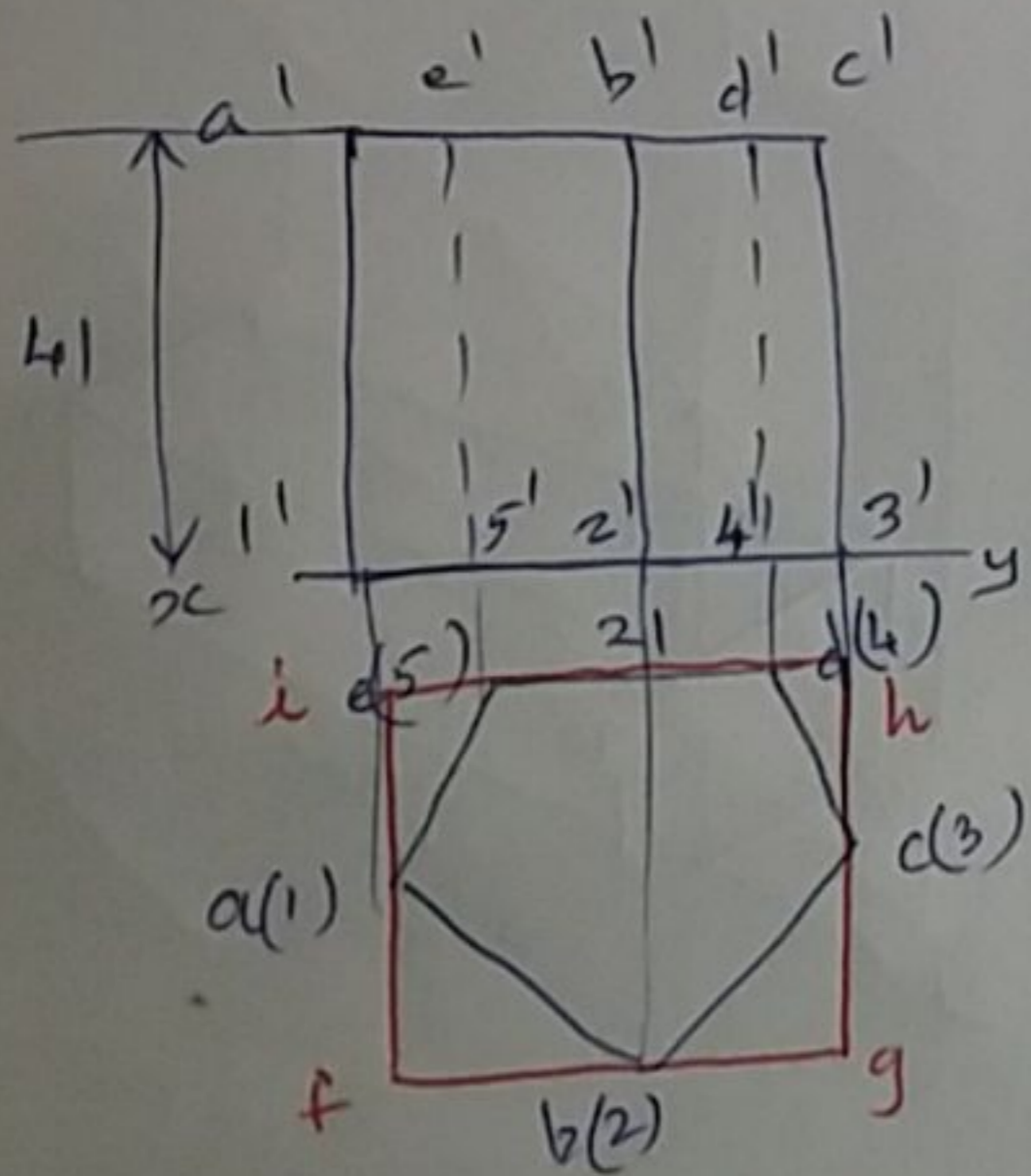
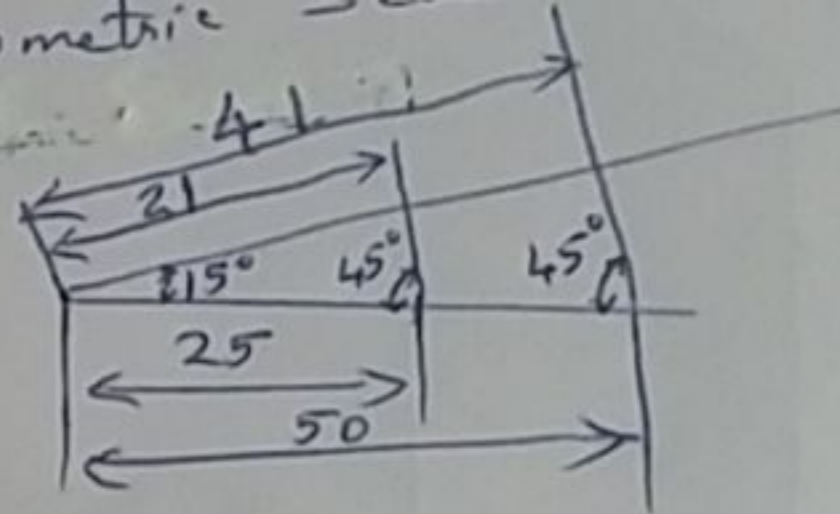

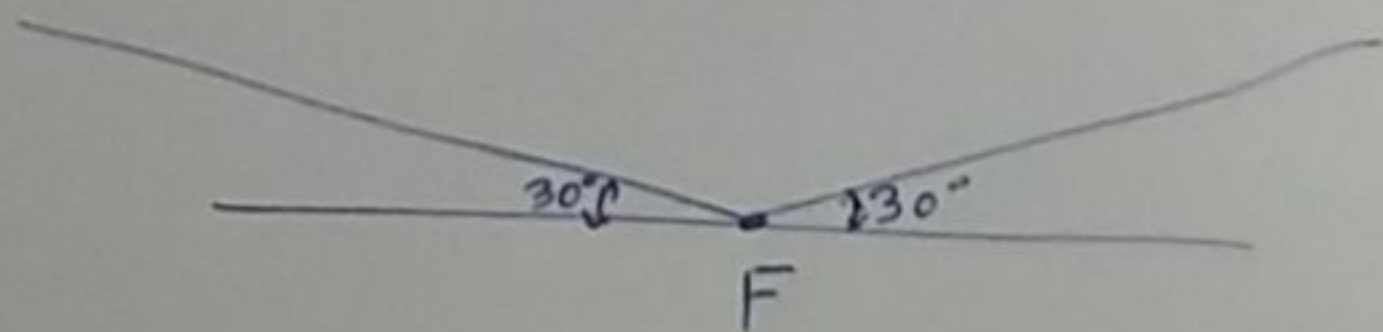
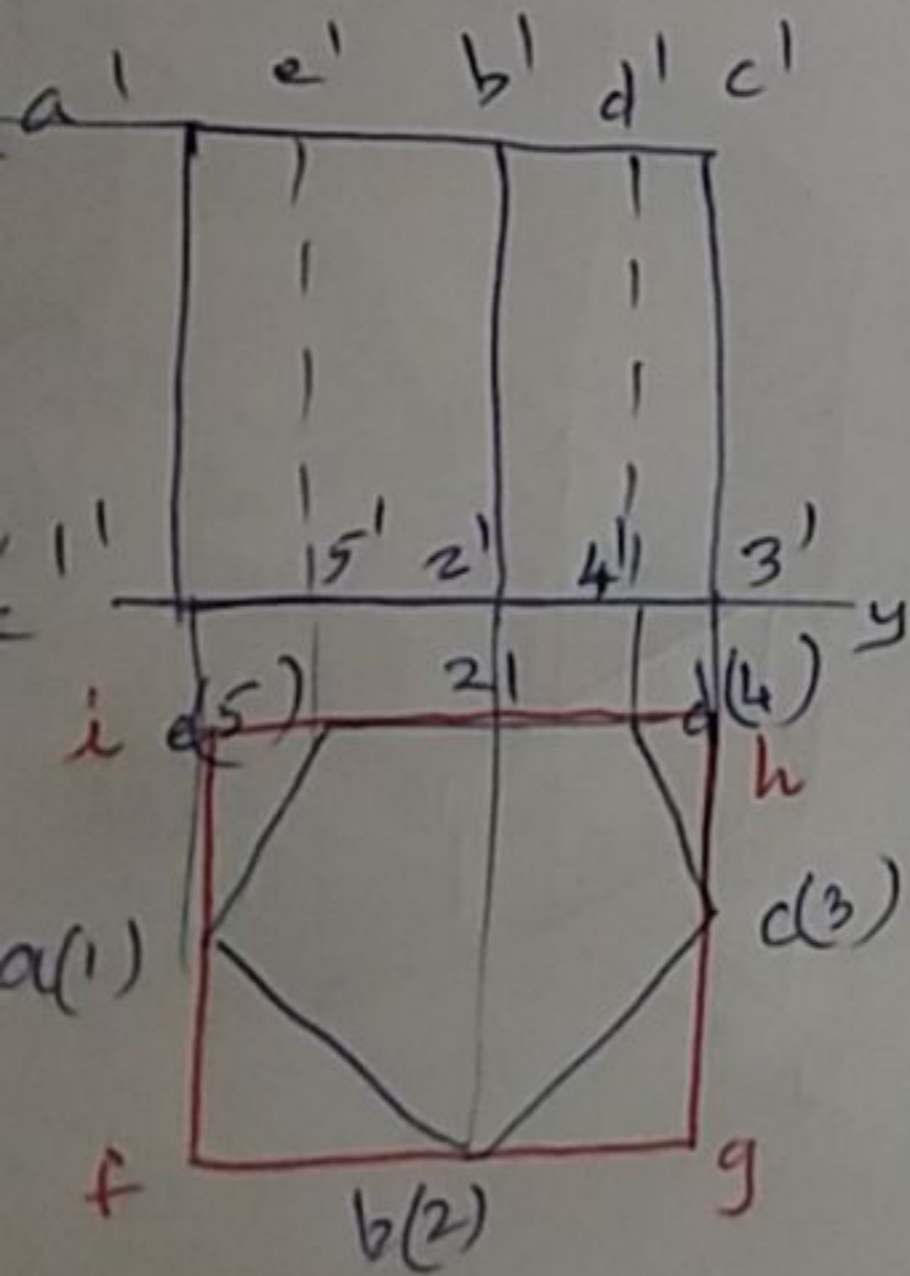

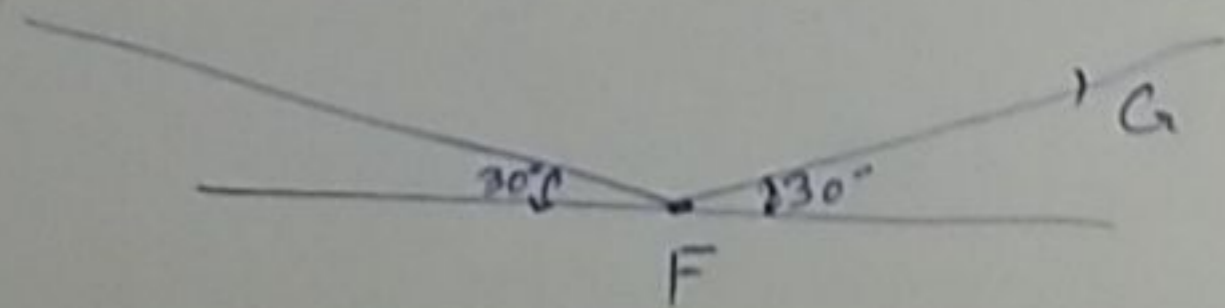
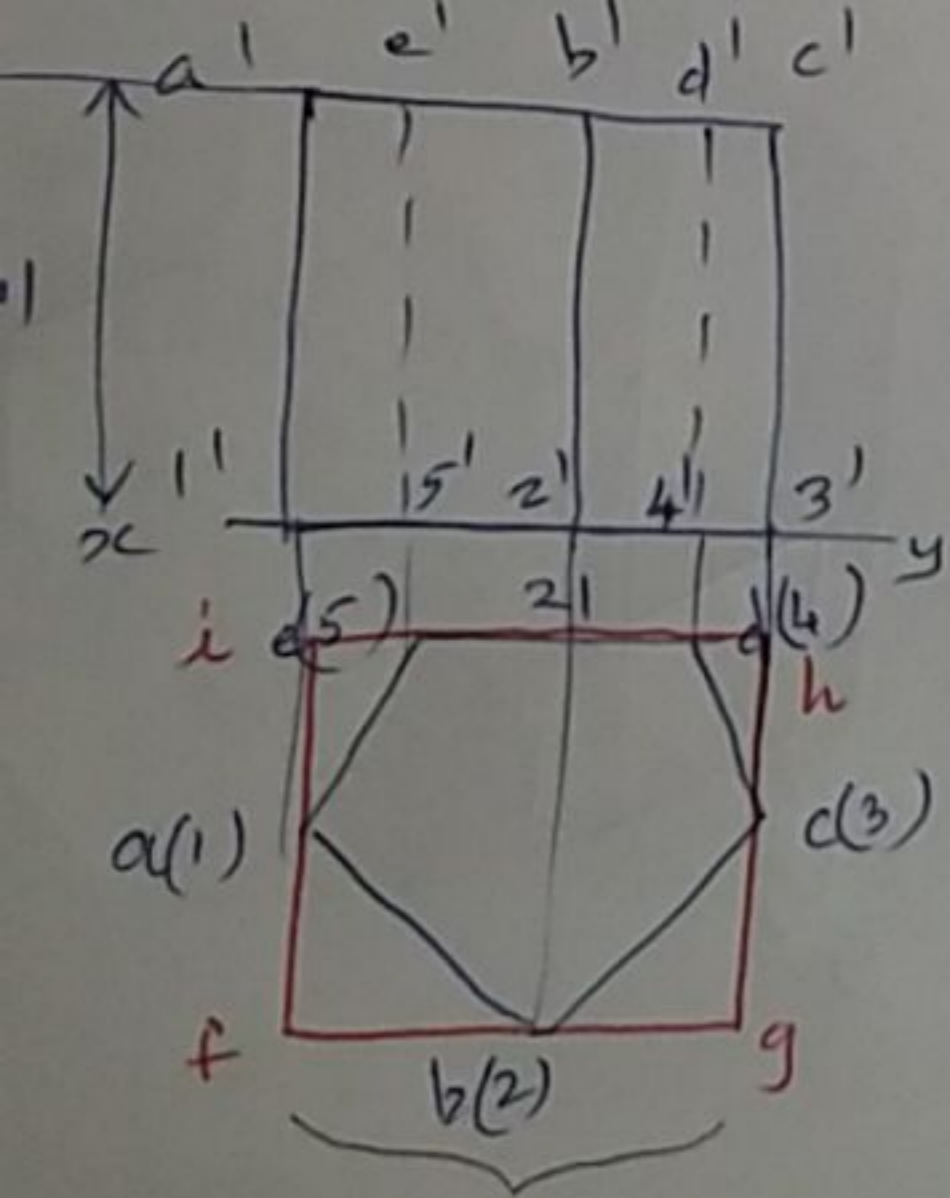

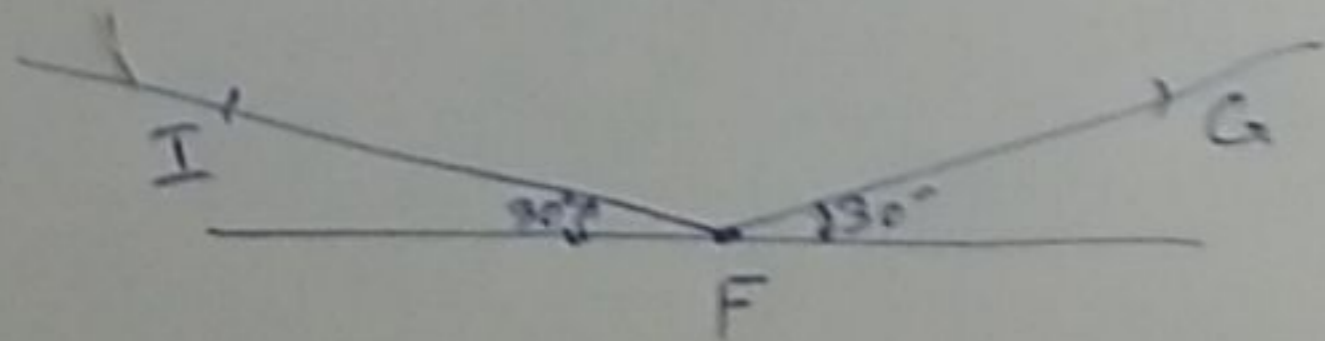
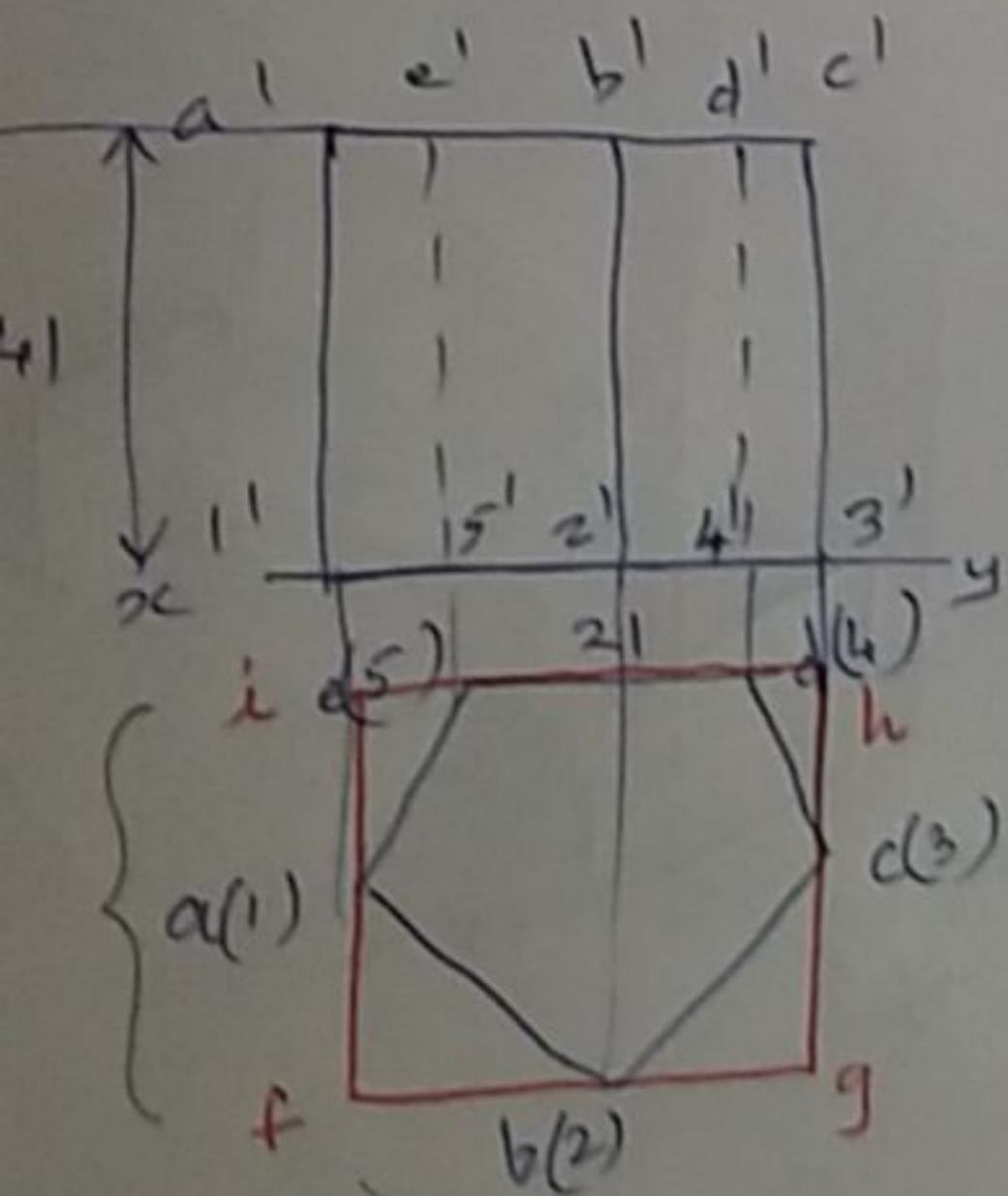

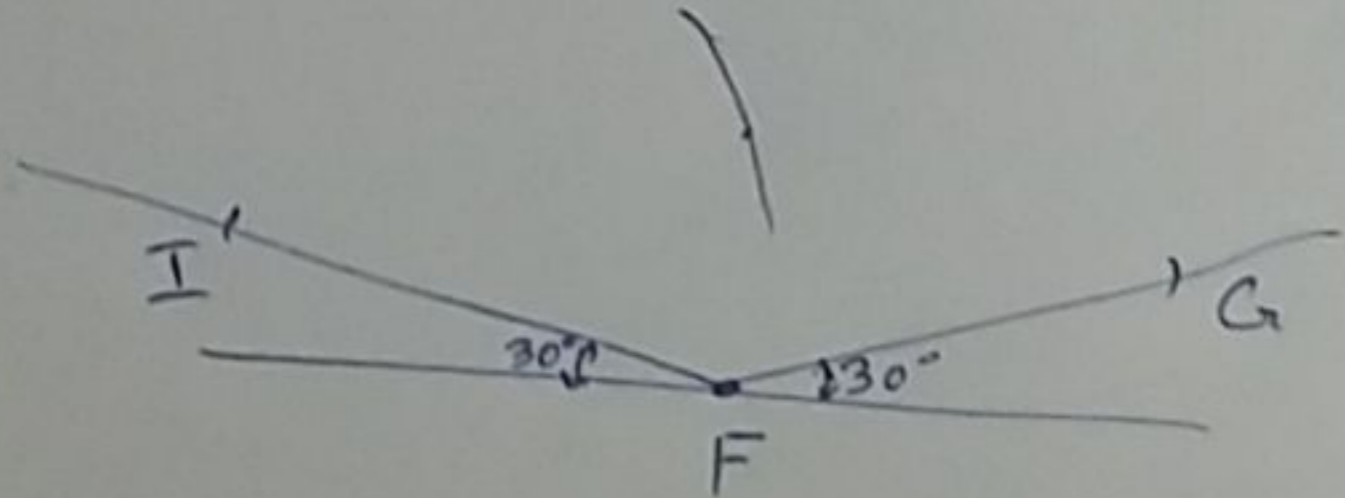
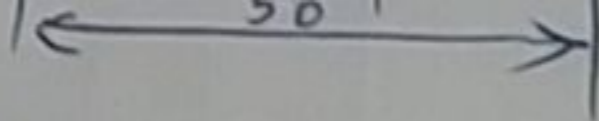
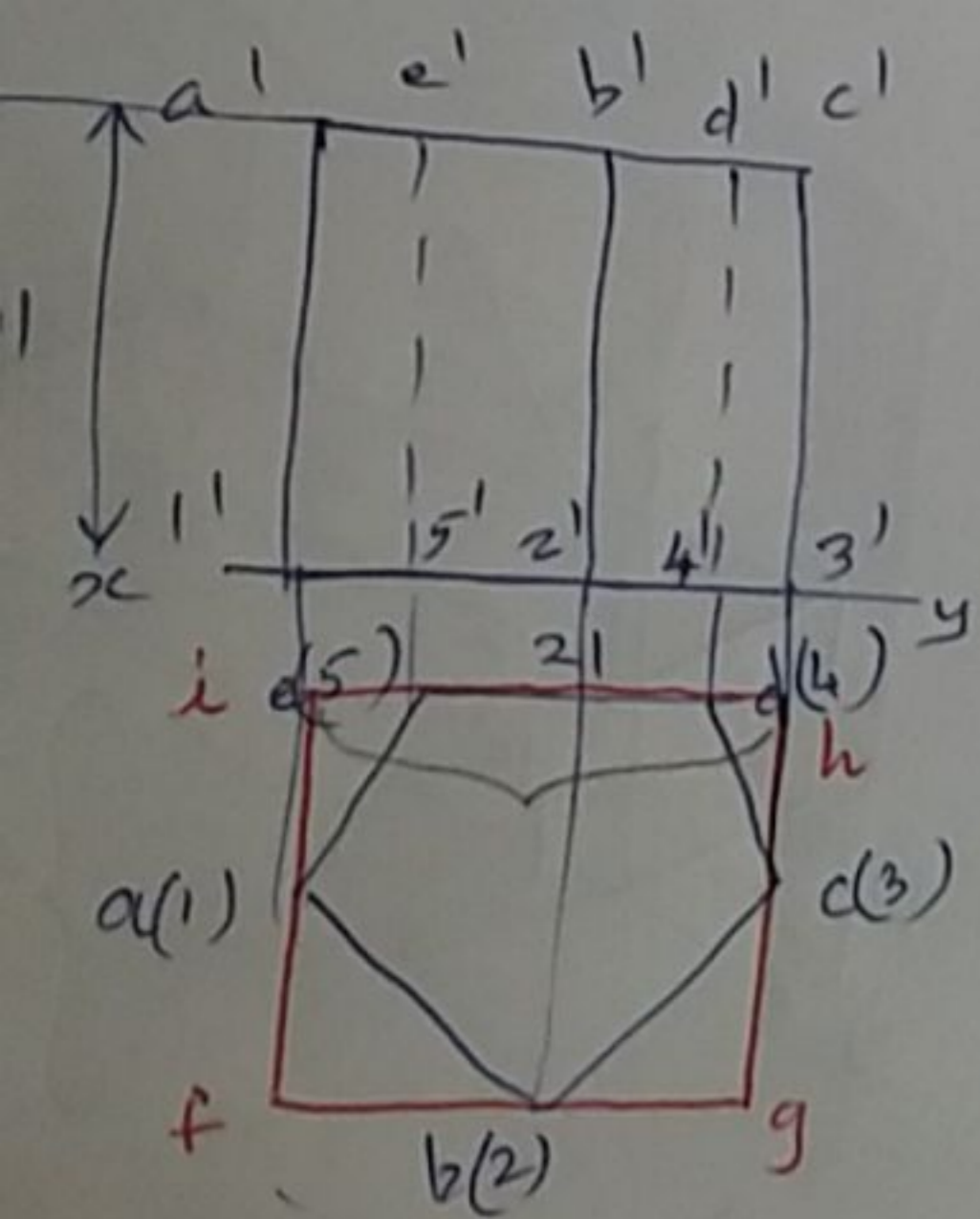

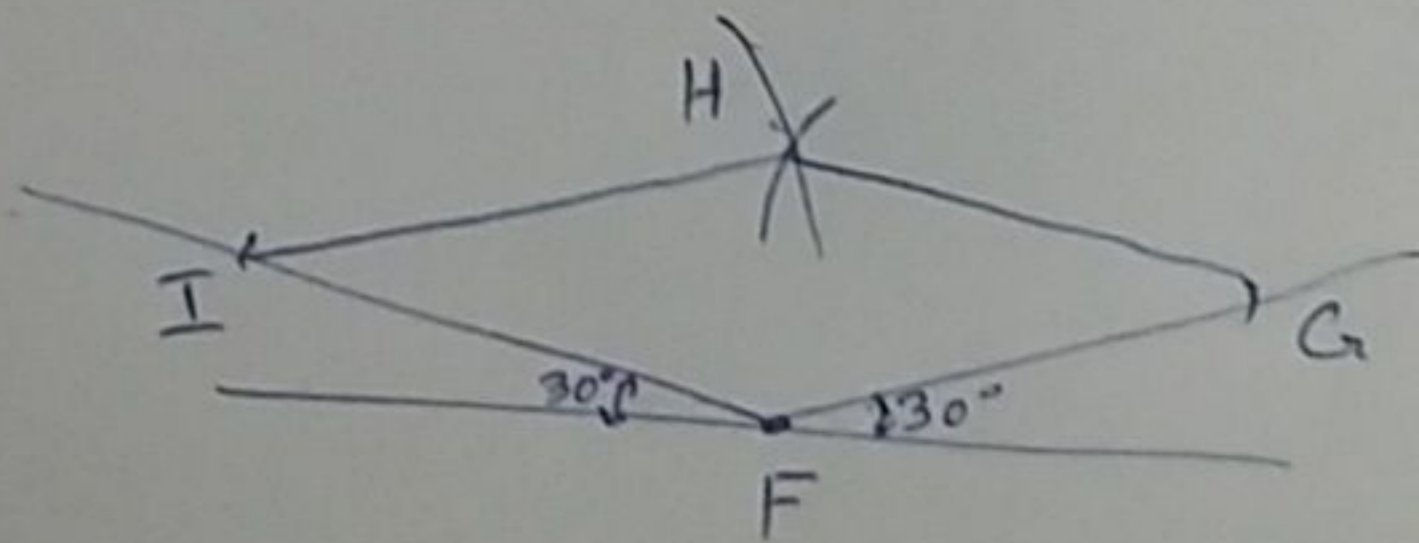
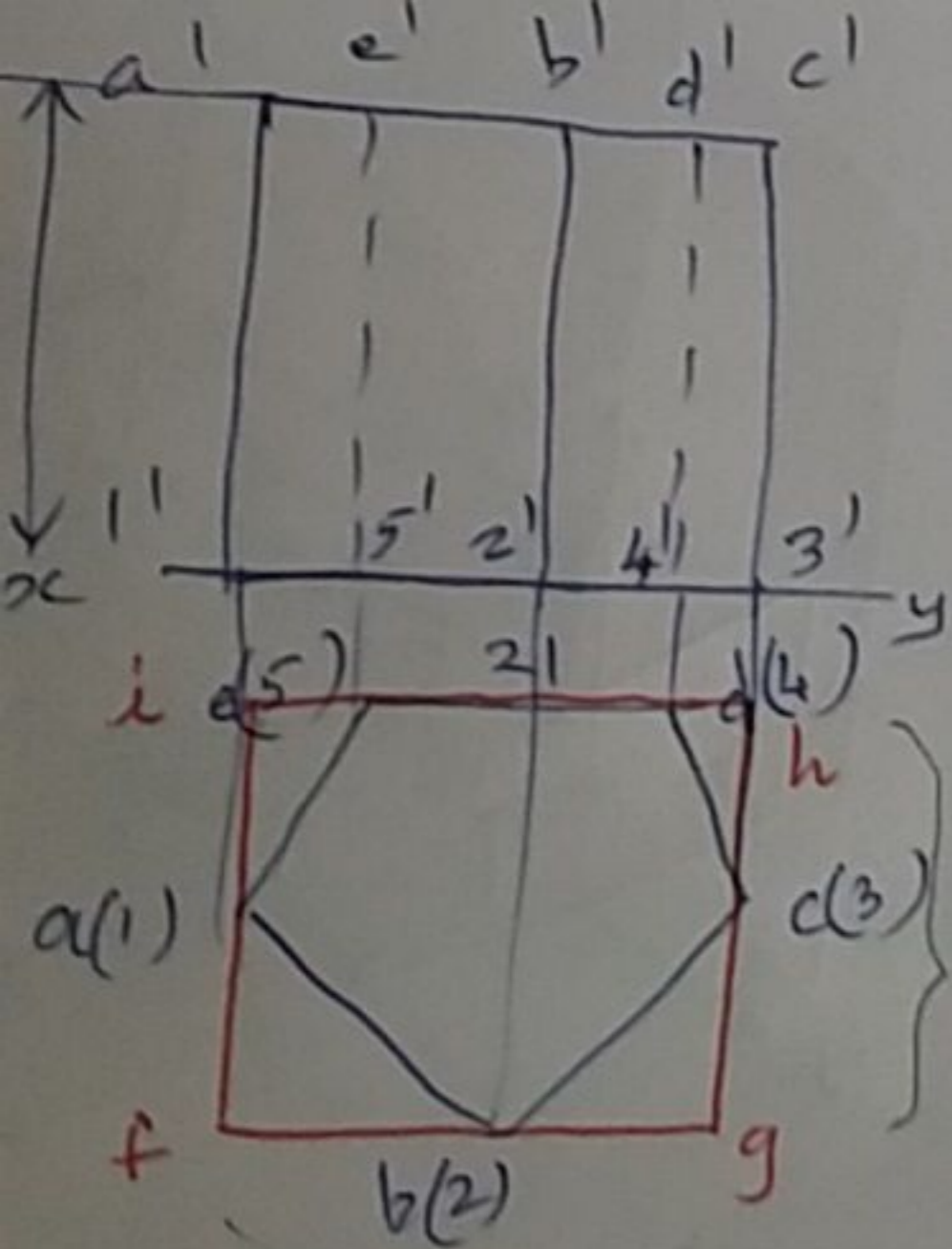

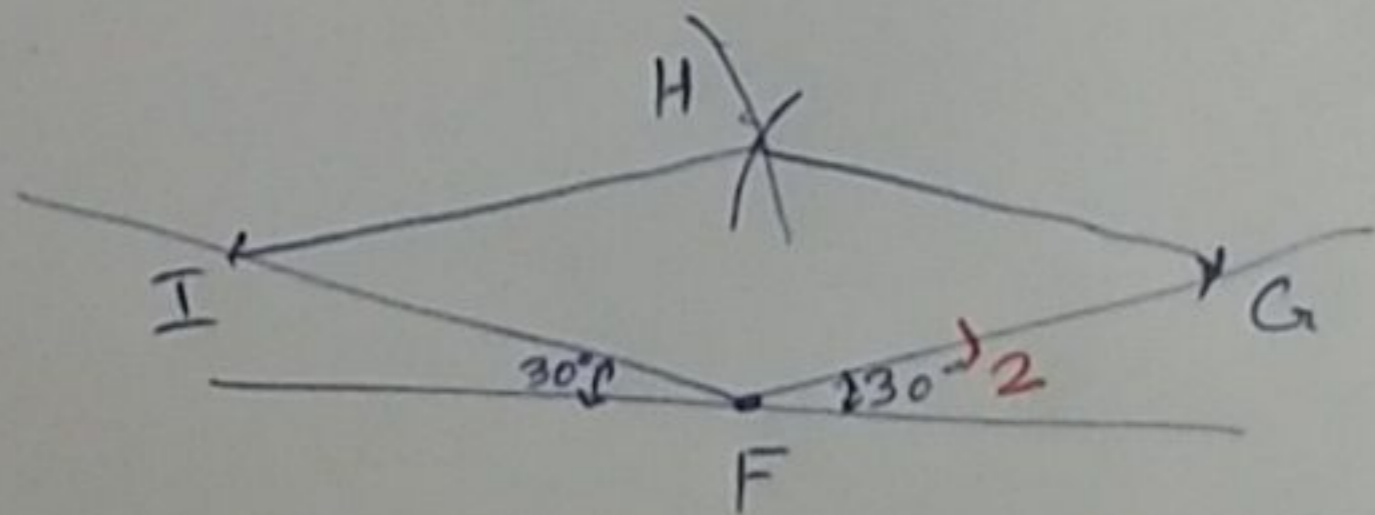
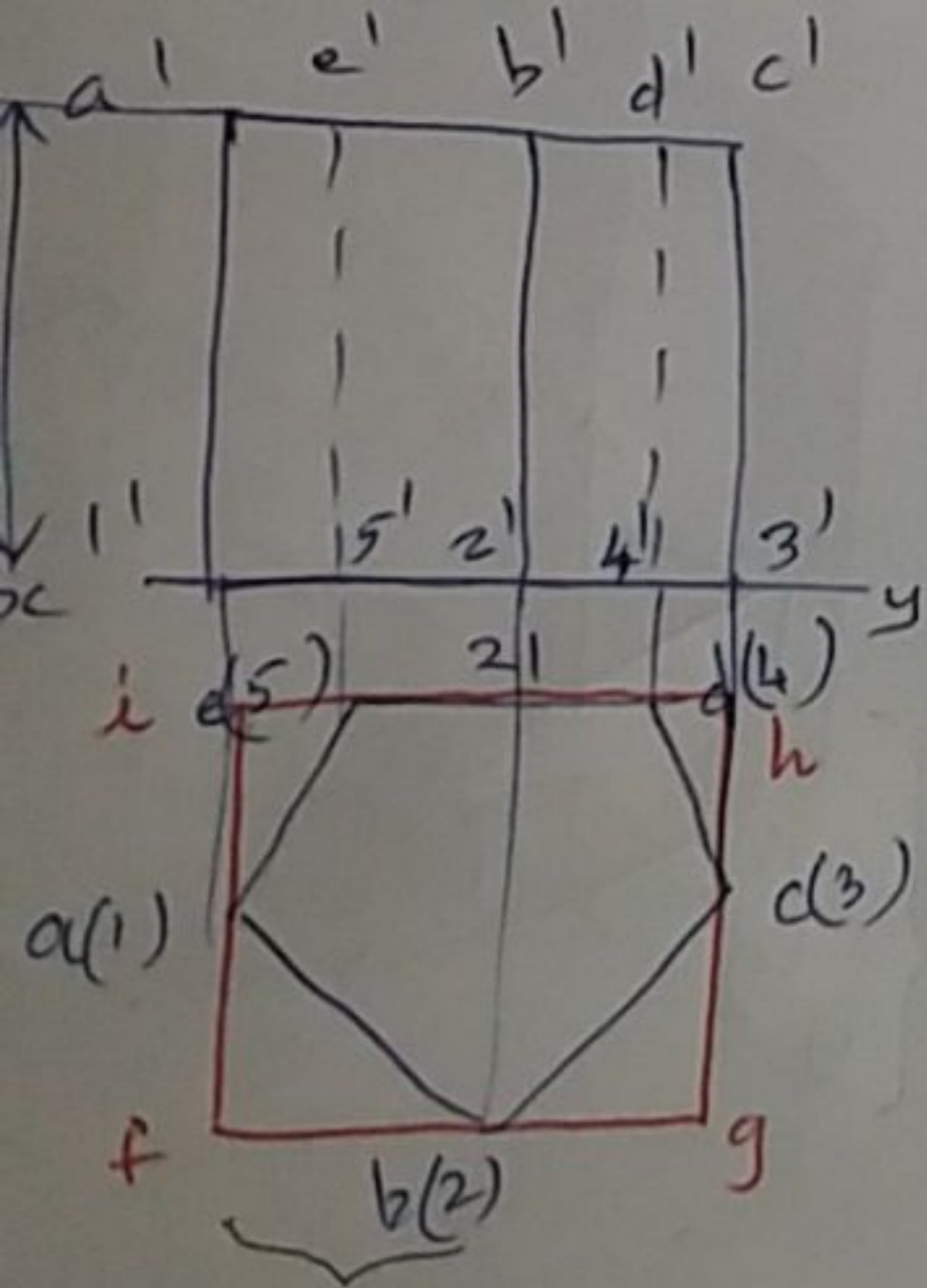

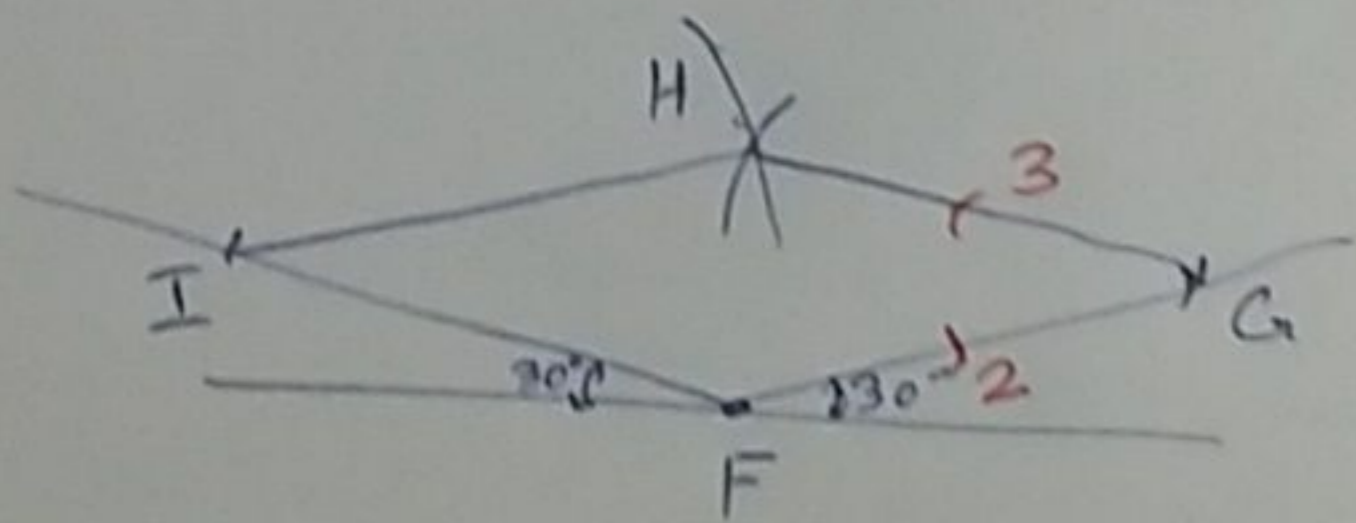
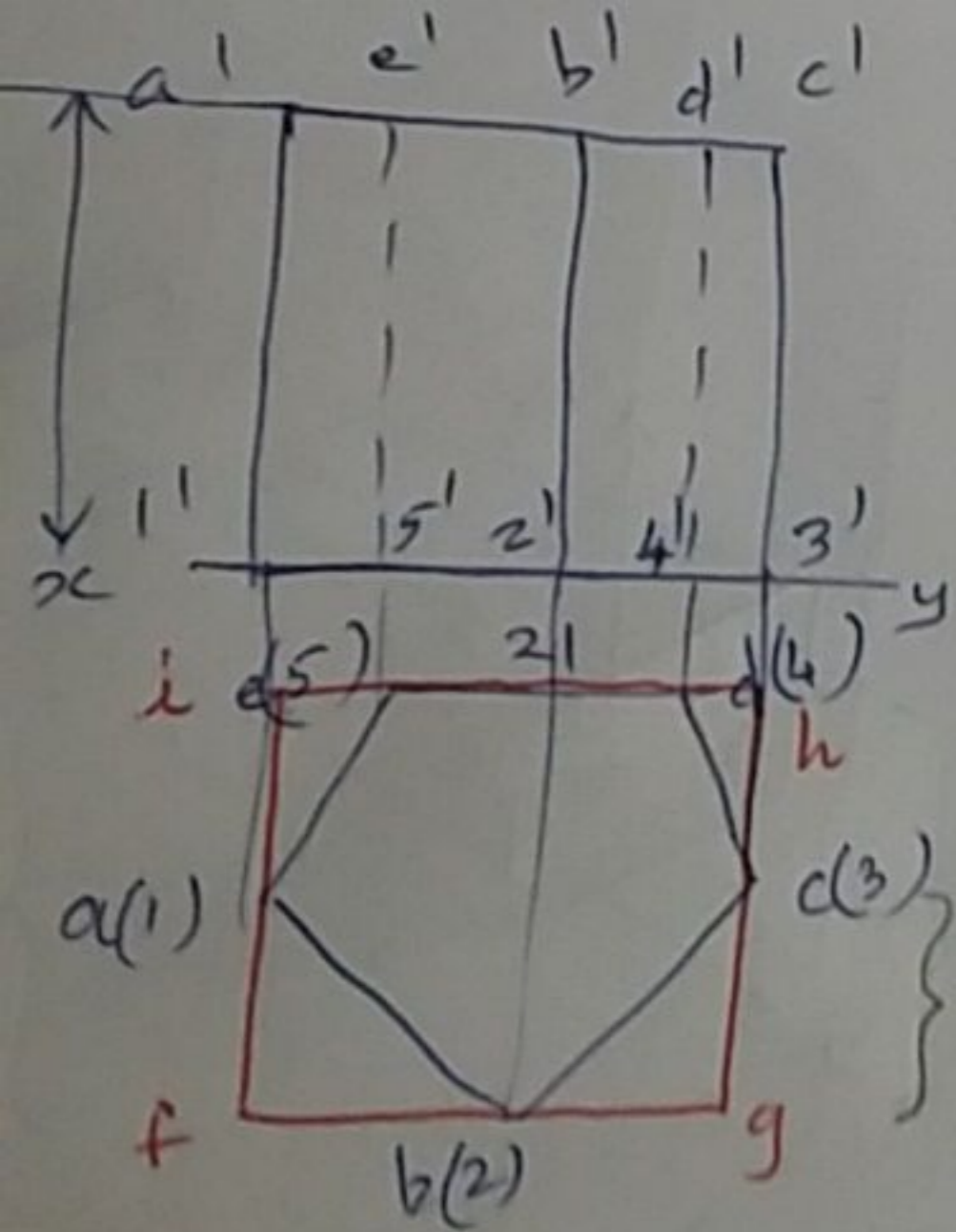

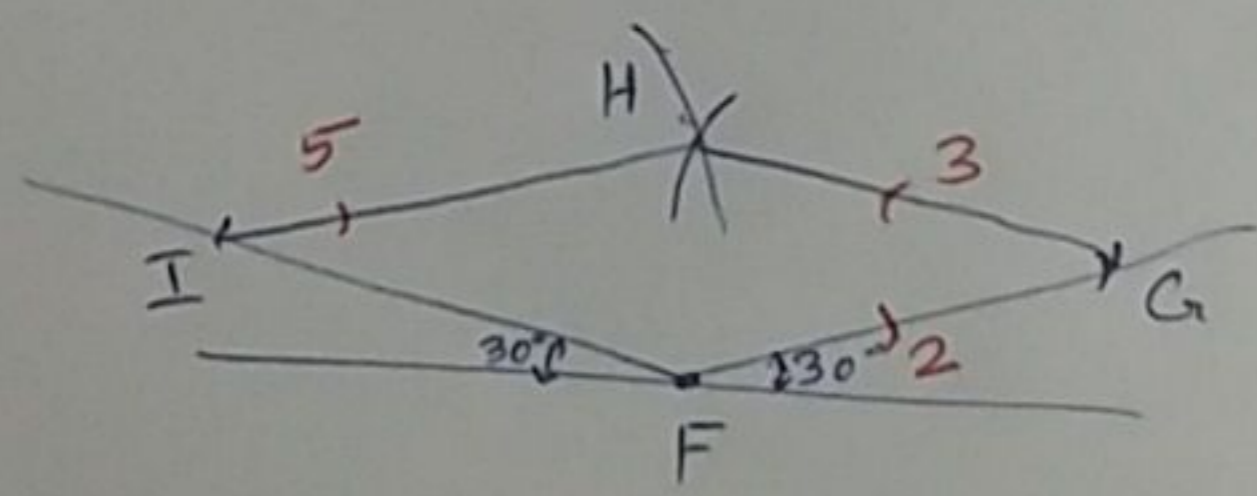
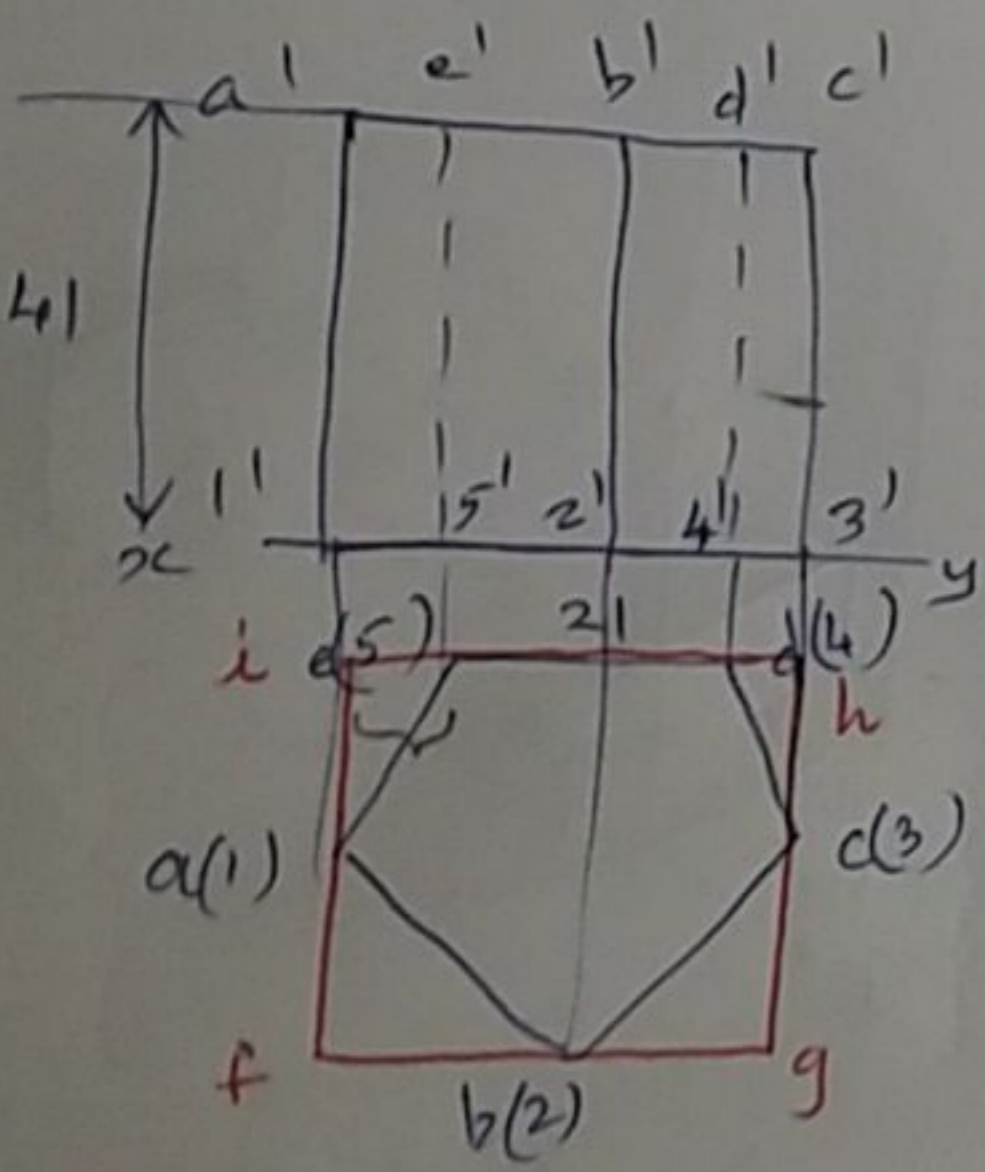

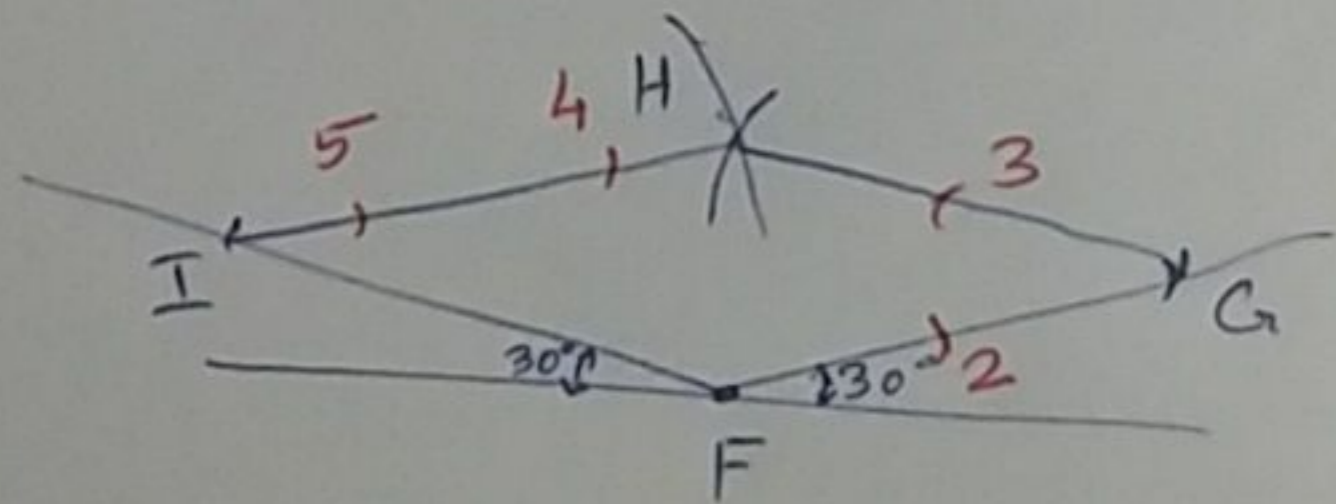
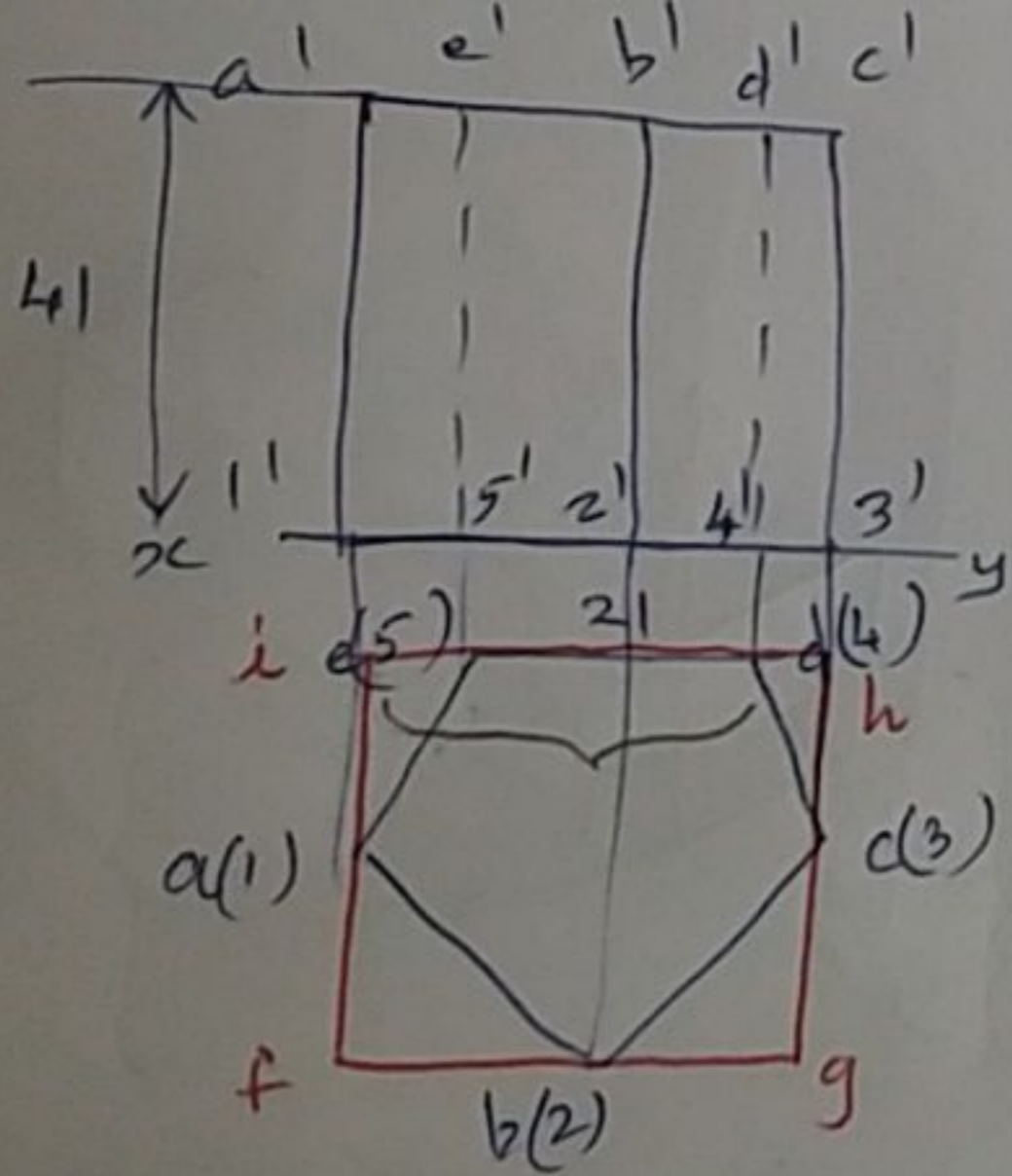

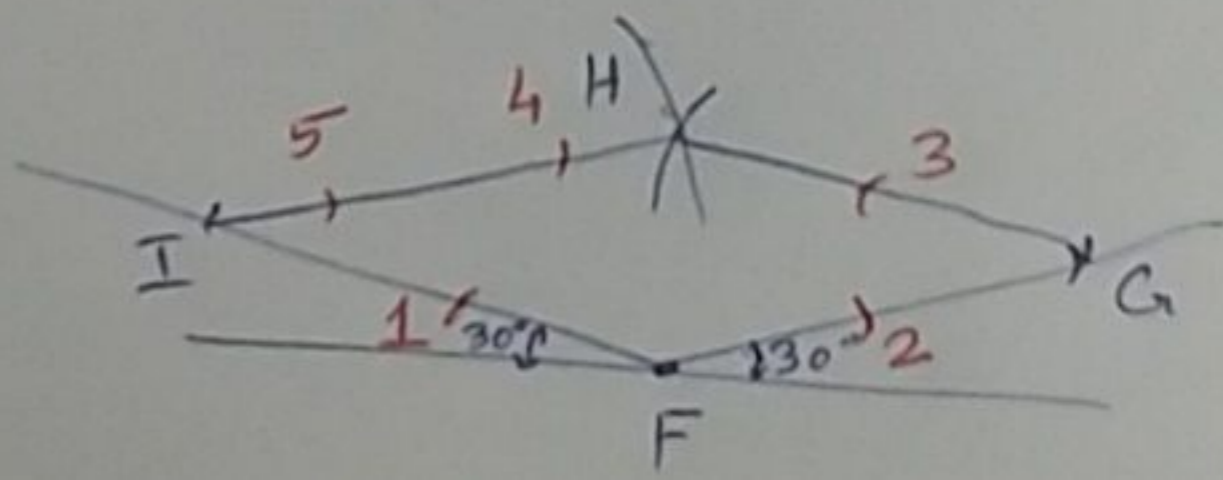
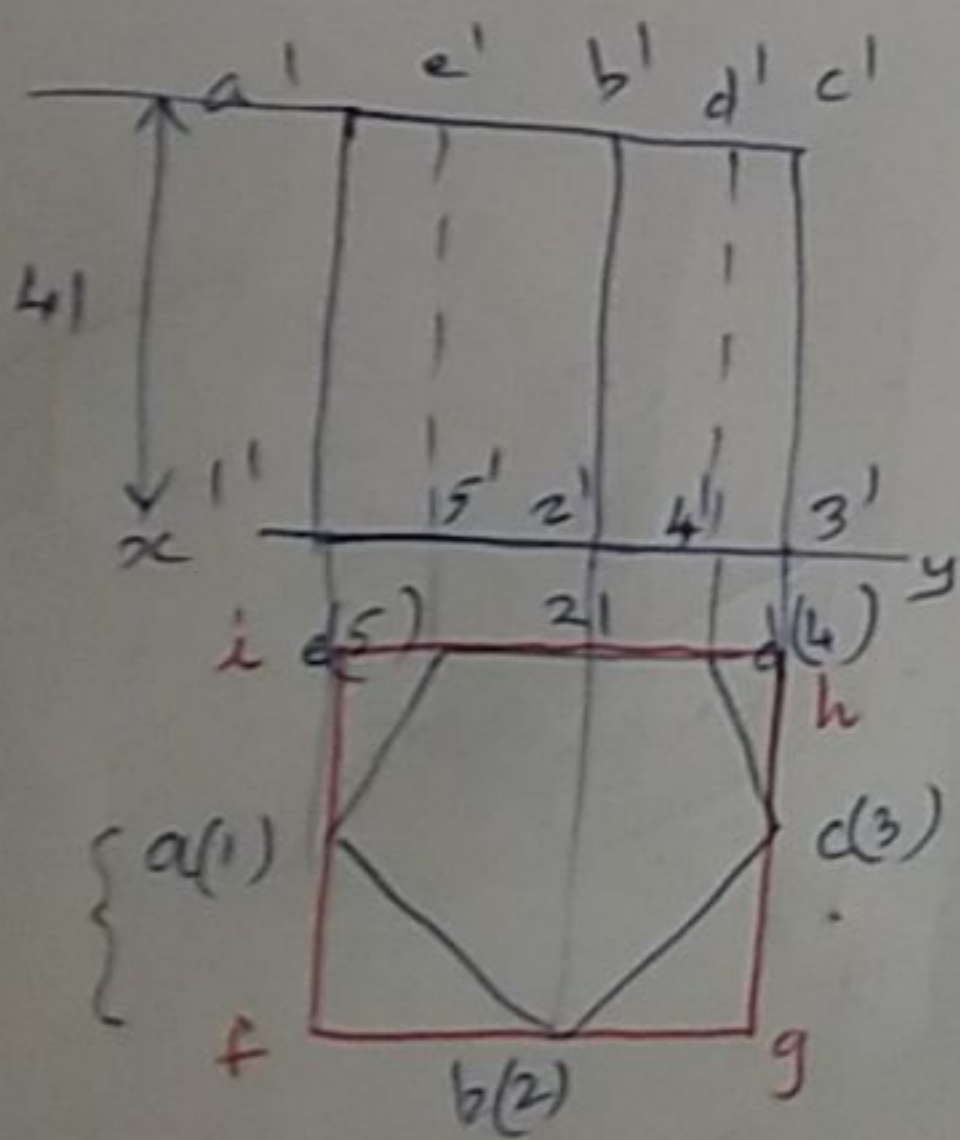

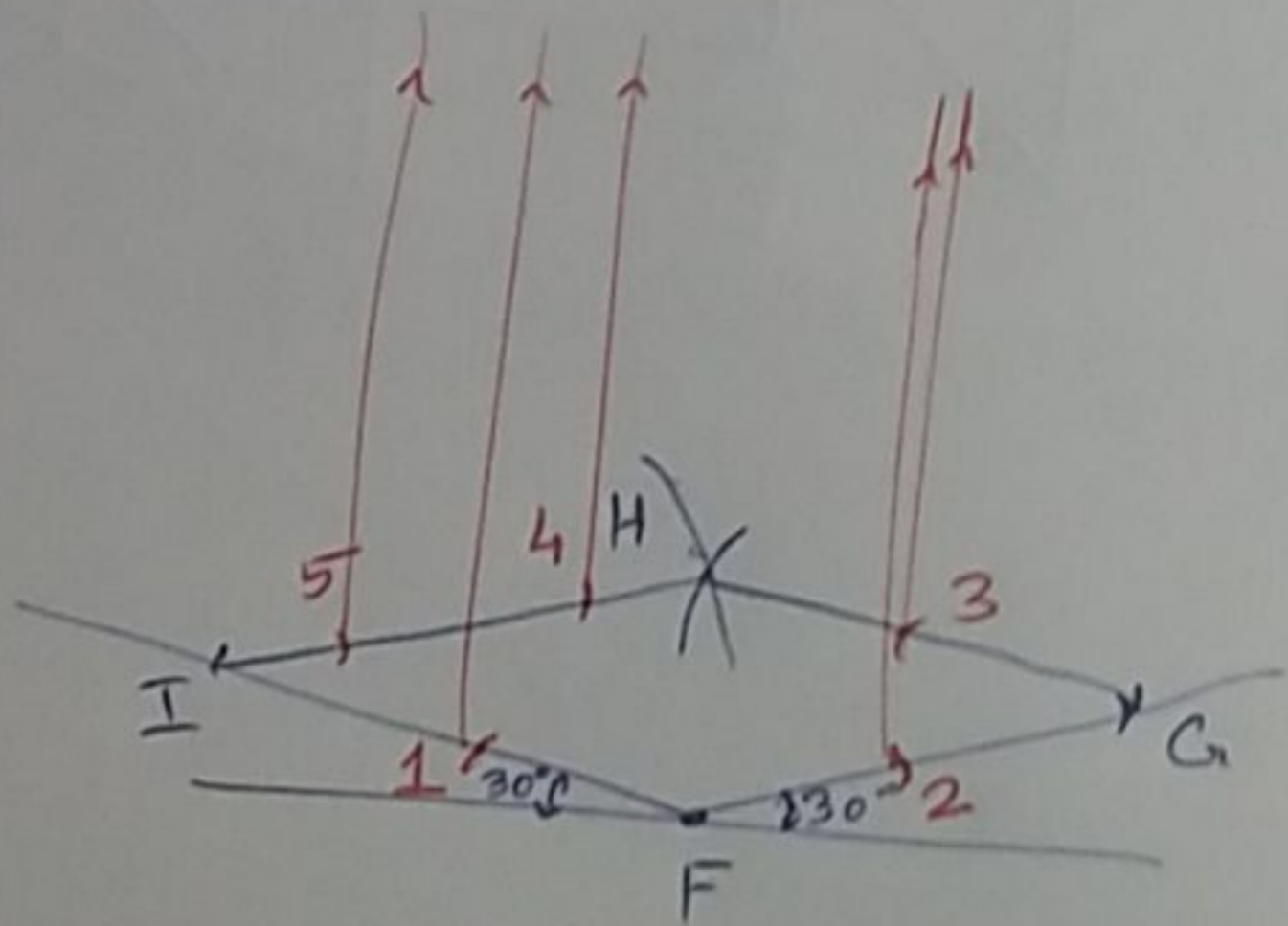
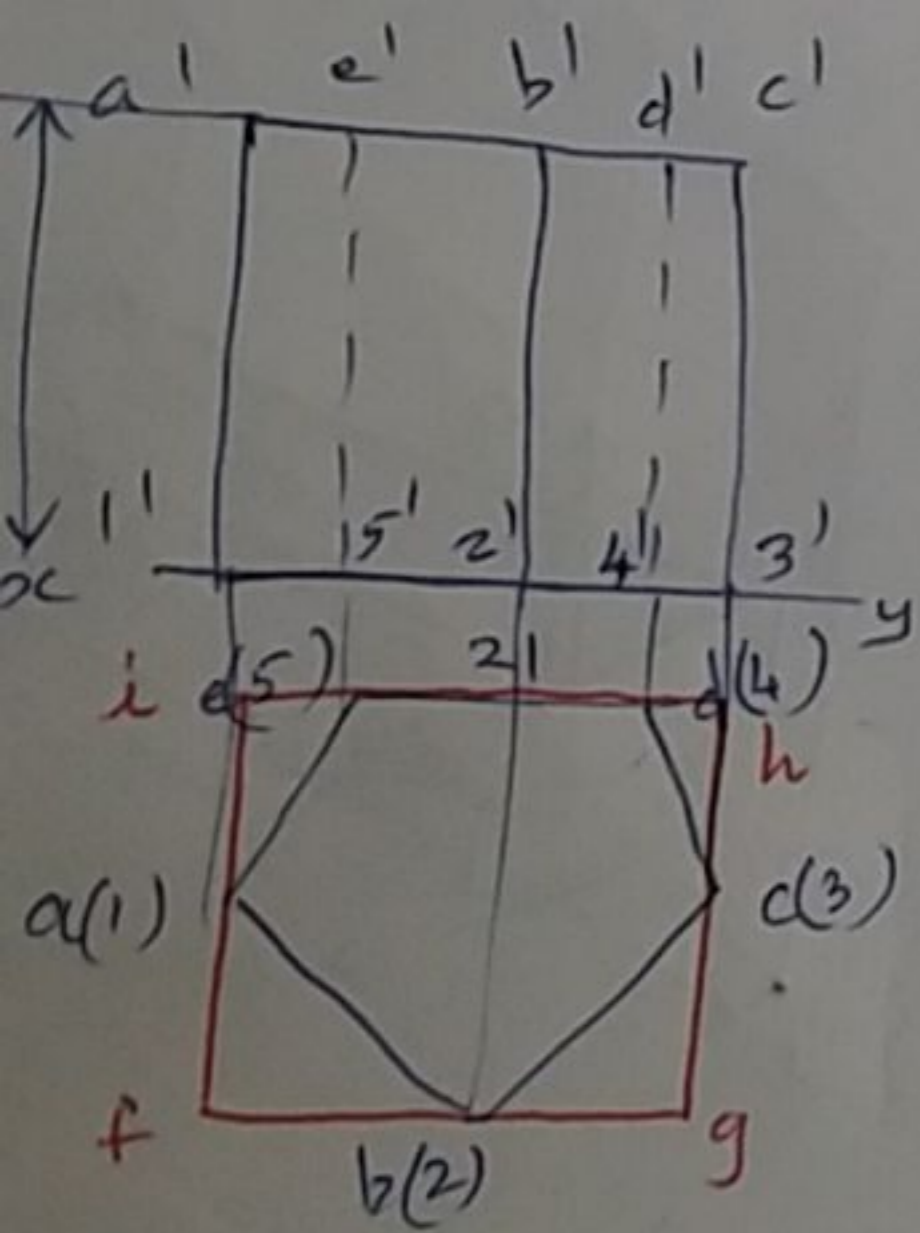

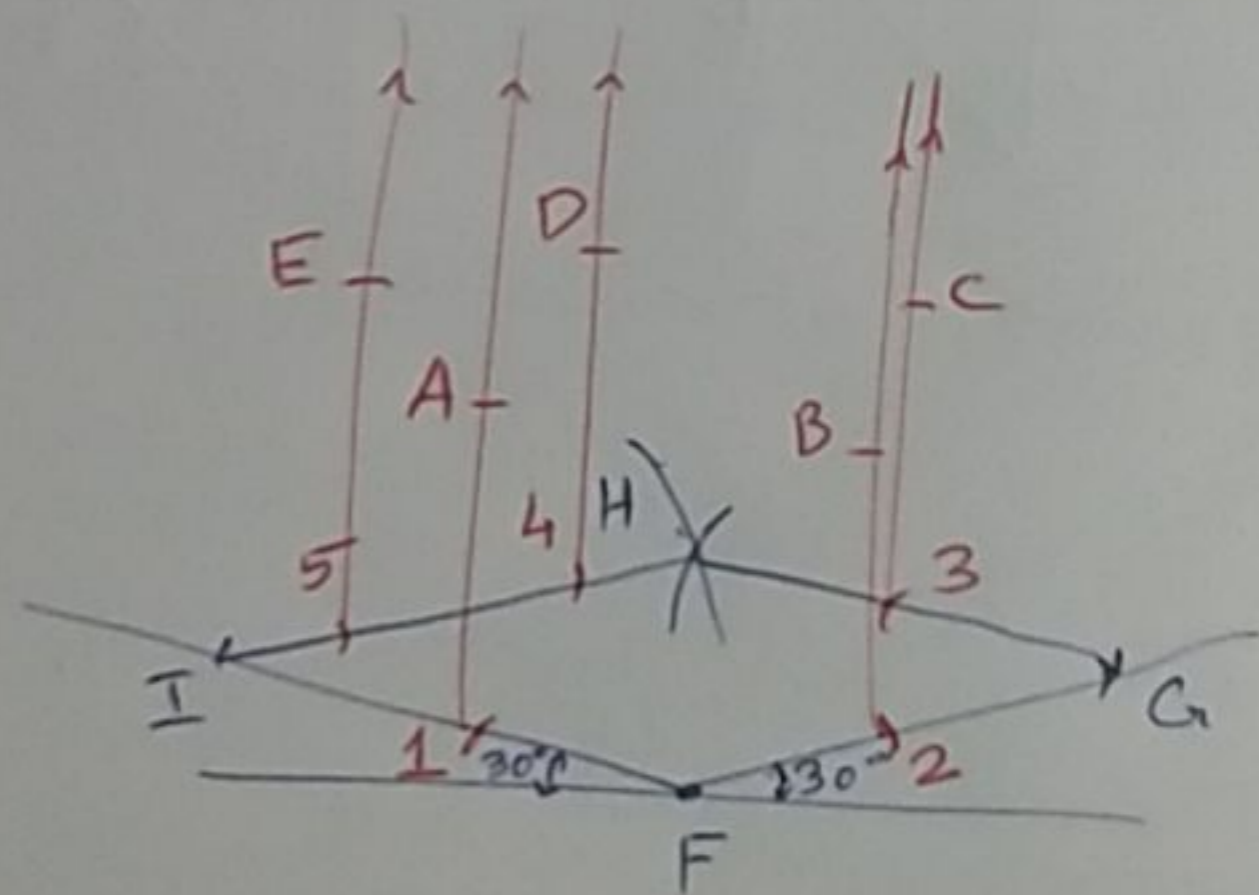
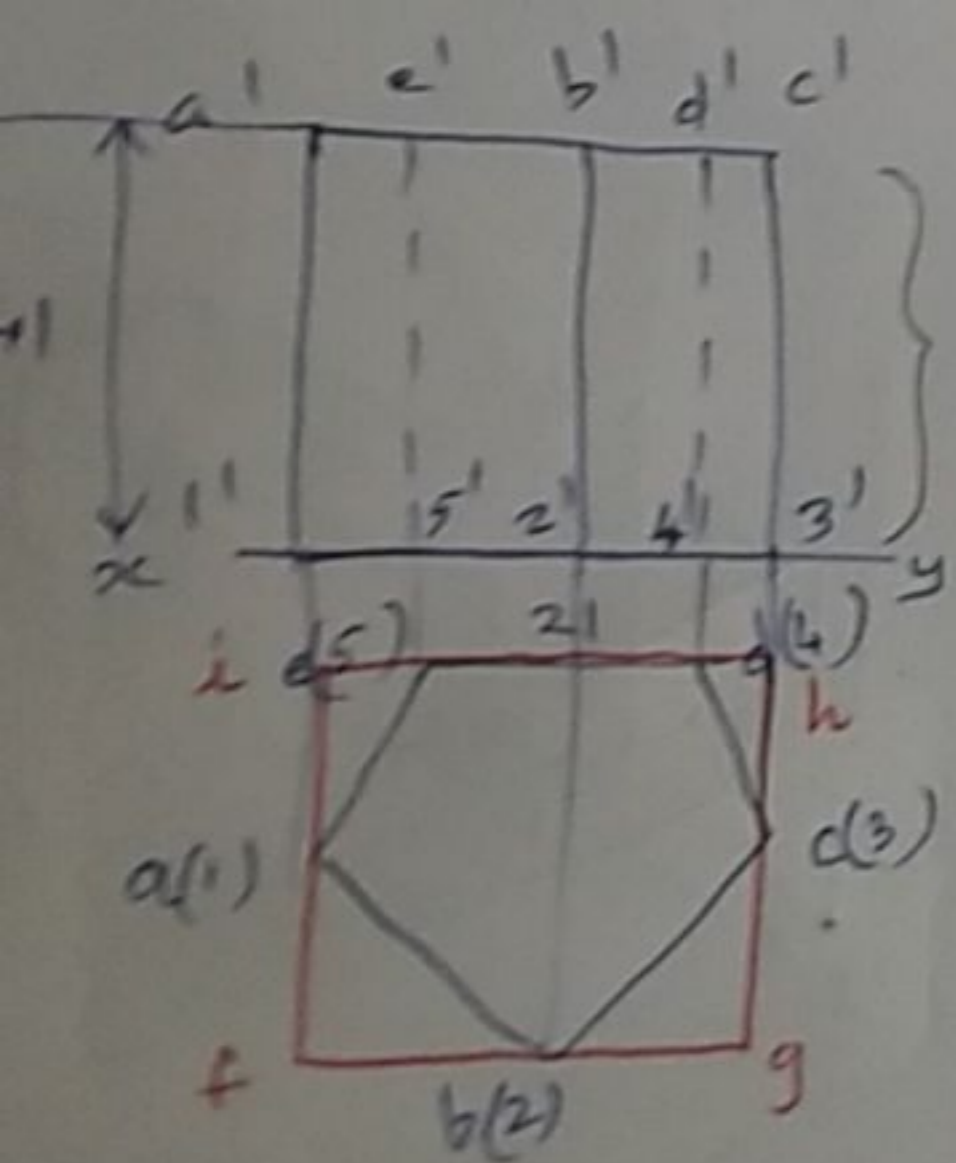

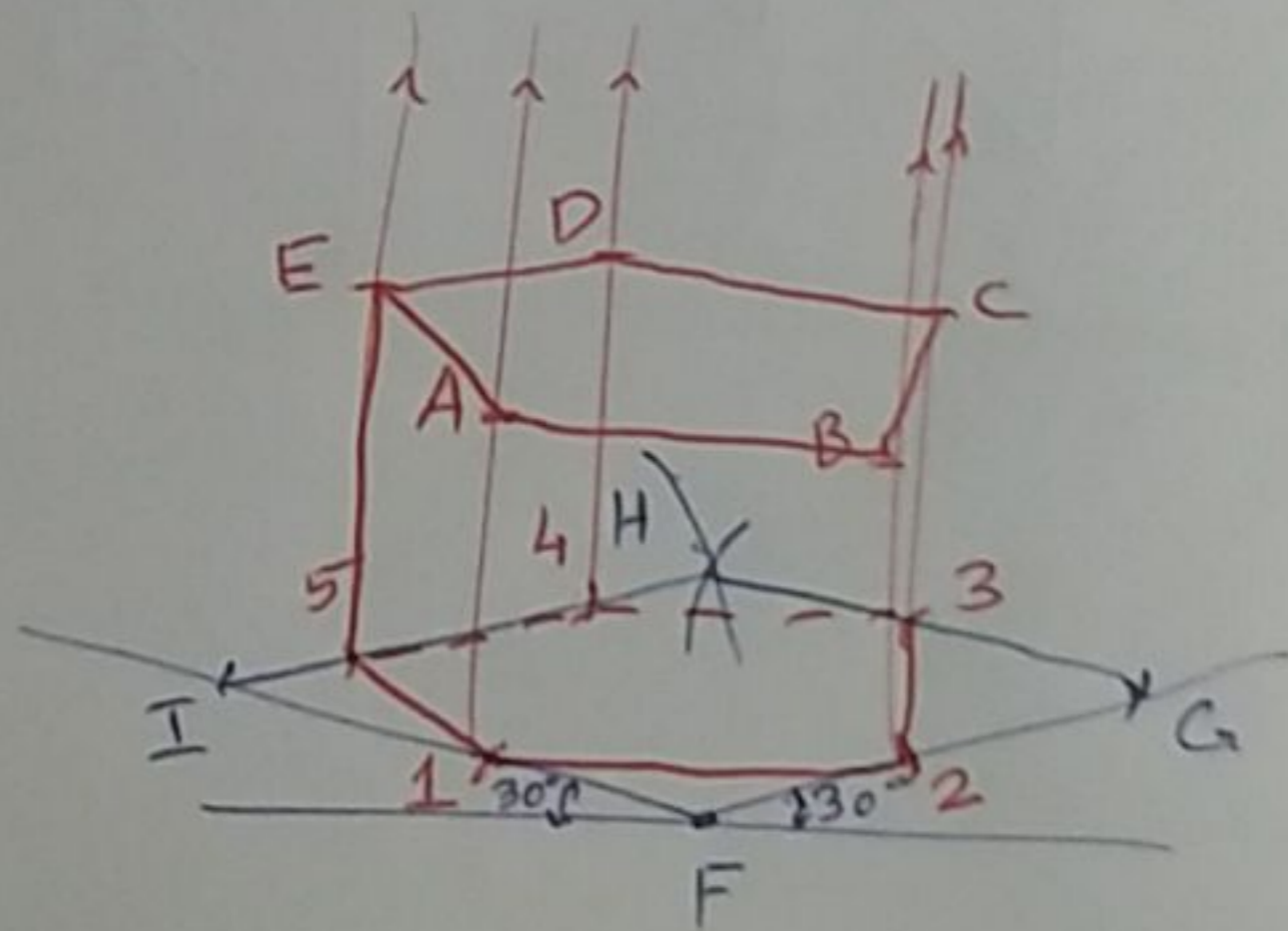
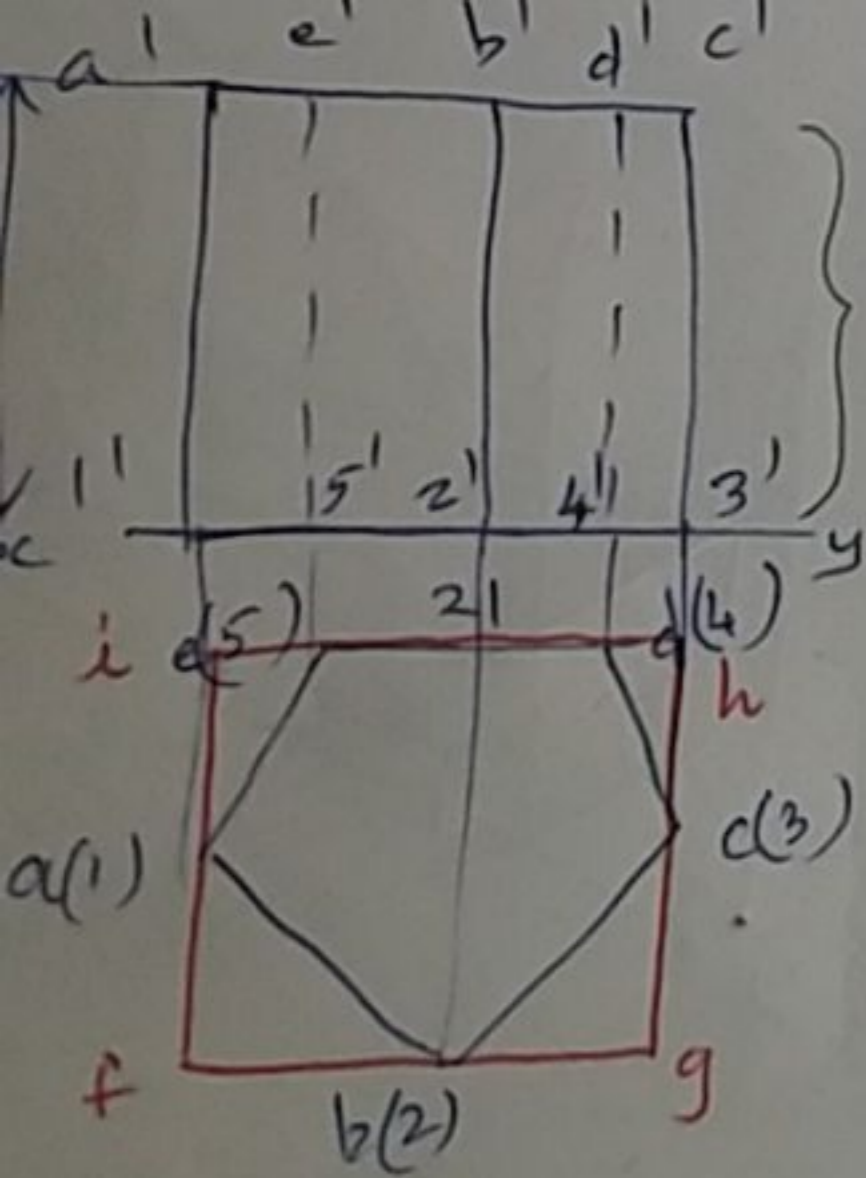

Isometric View

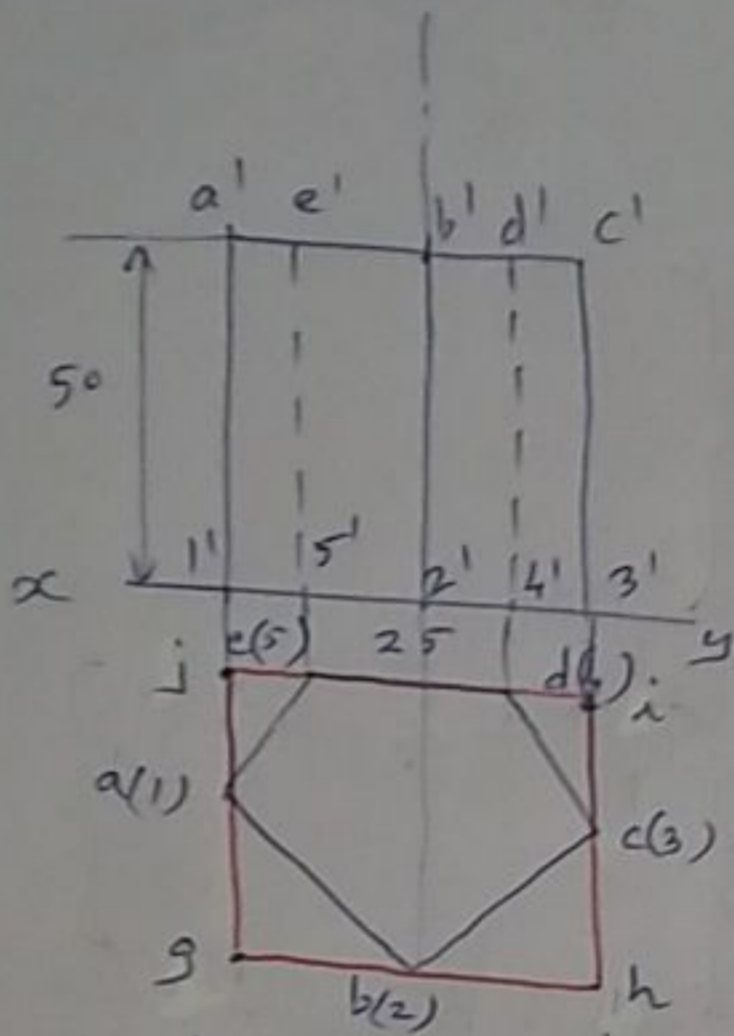

Orthographic projection

Isometric projection

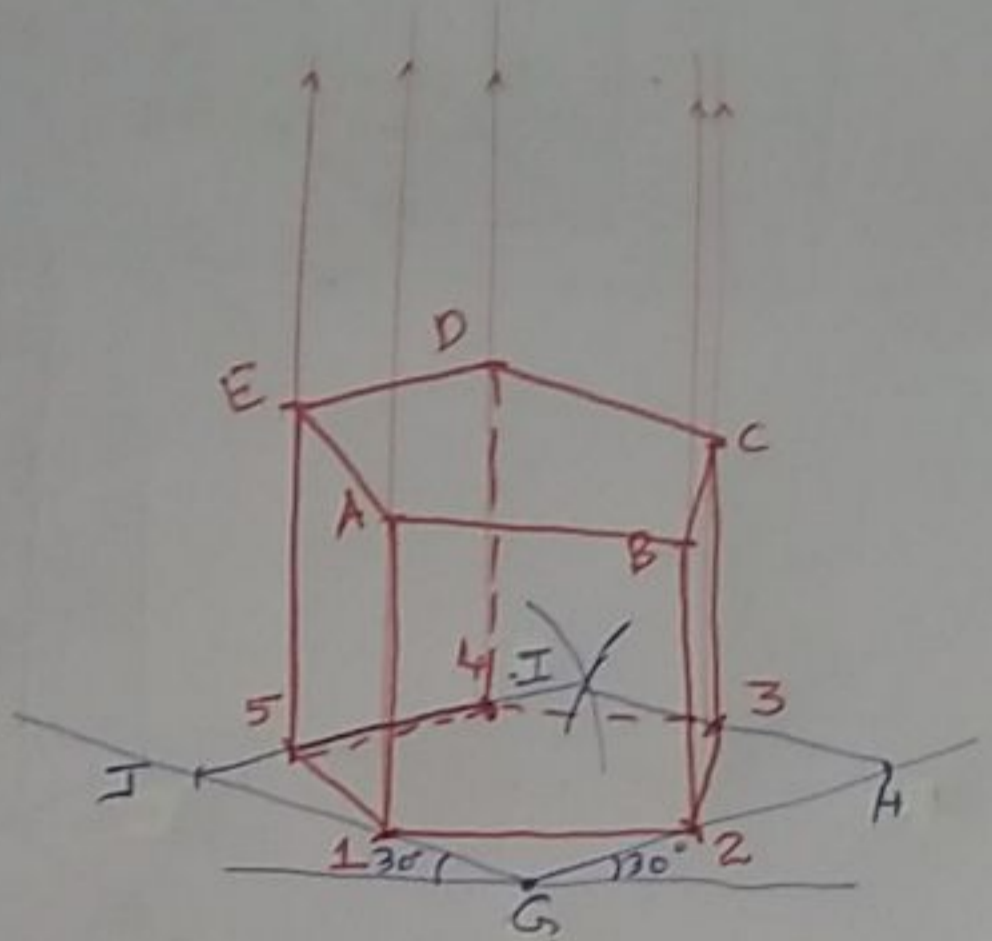
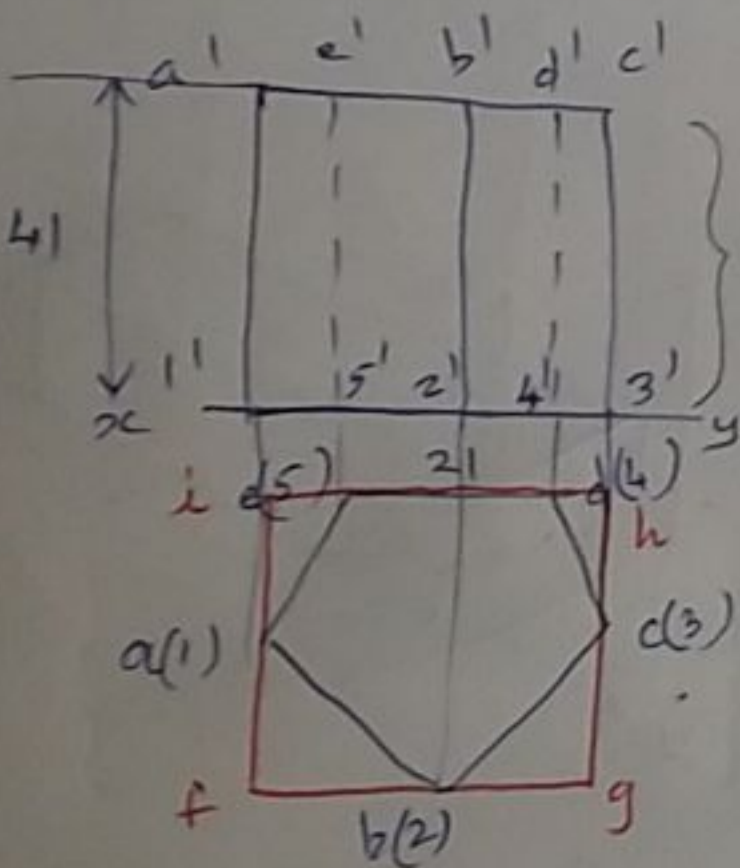

Isometric View

Isometric Scale

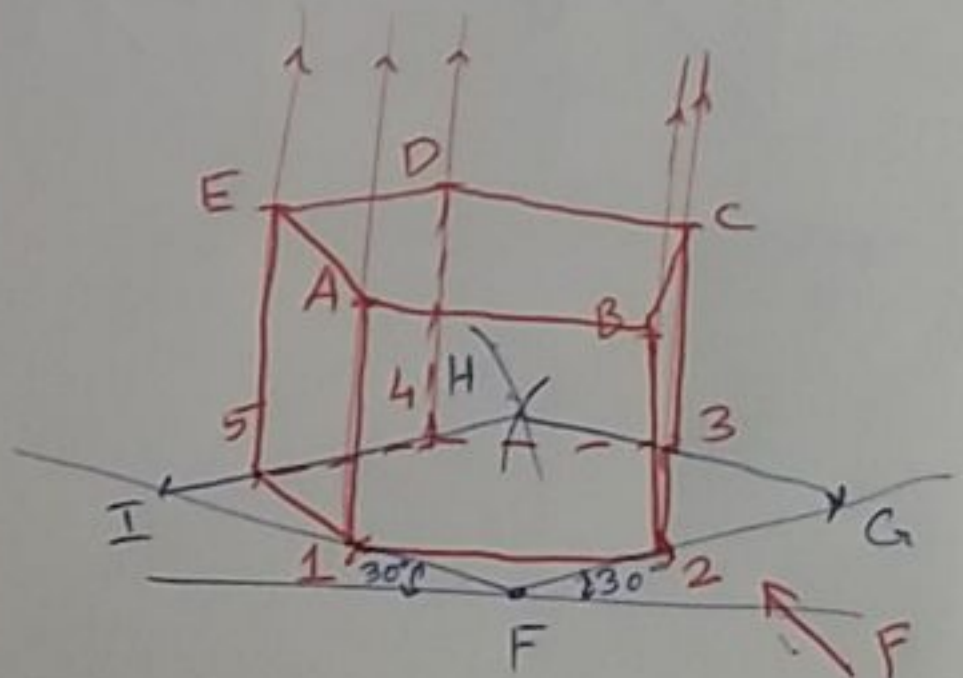
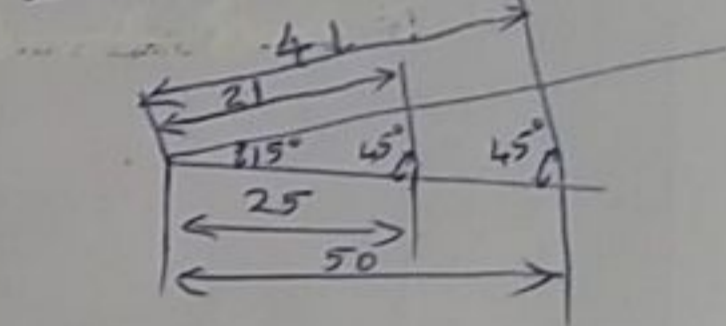

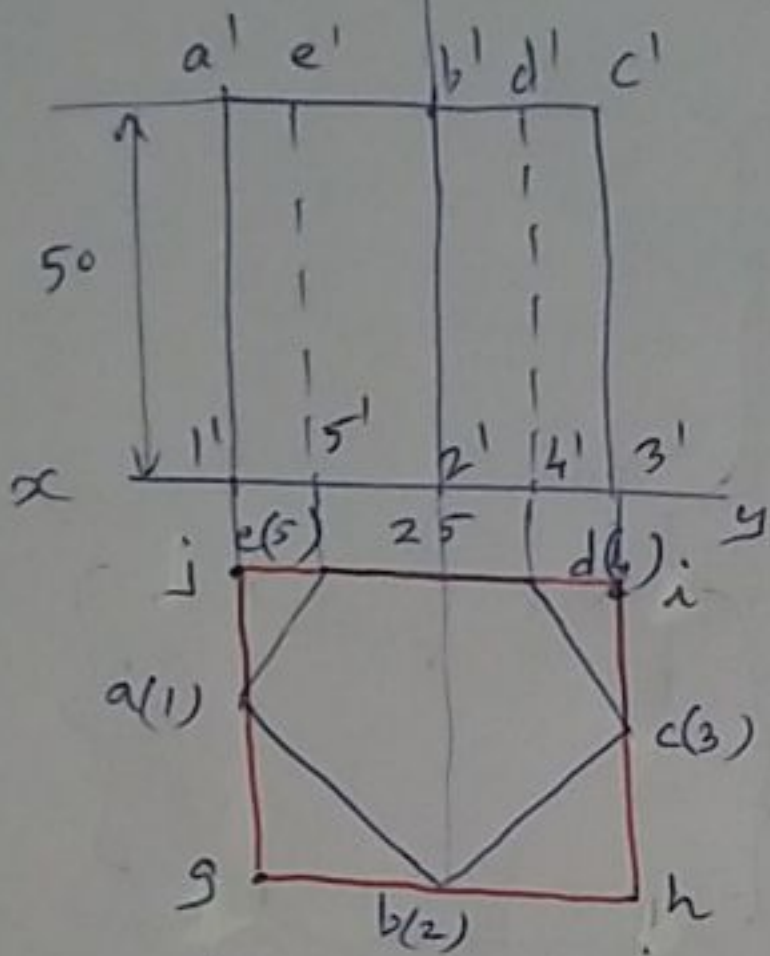

Orthographic projection

Isometric projection

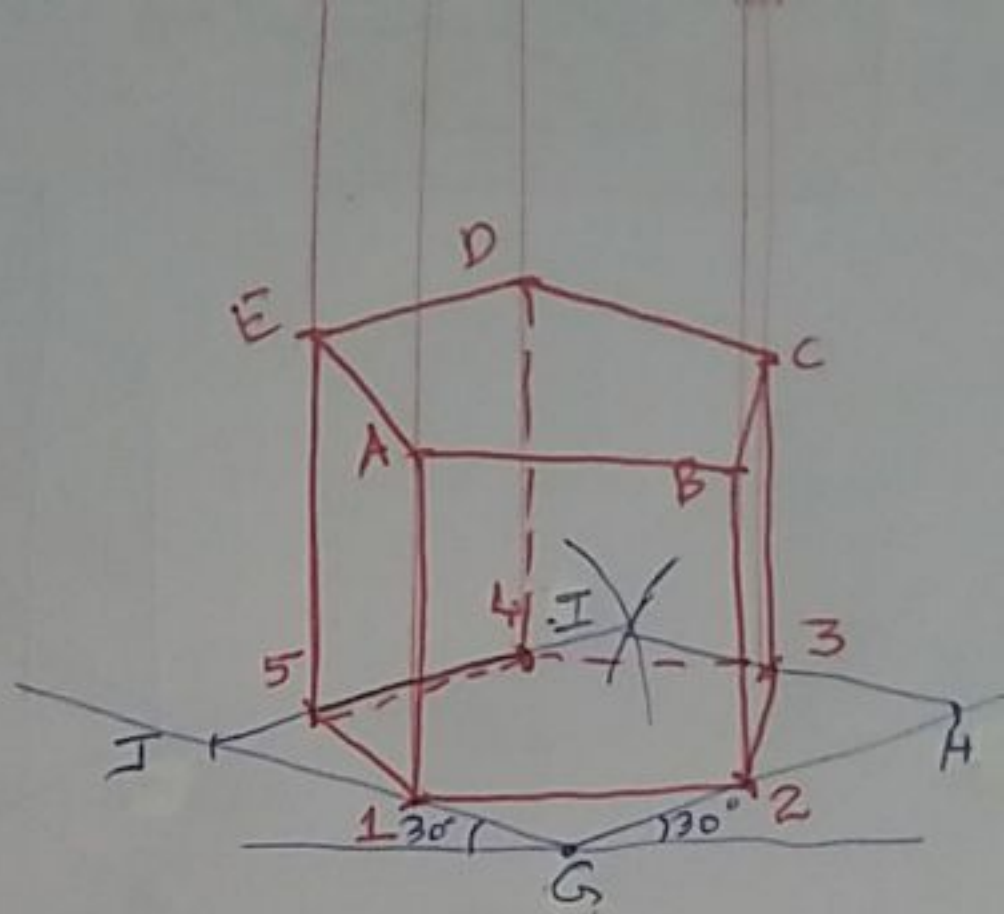

Isometric View

Isometric Scale

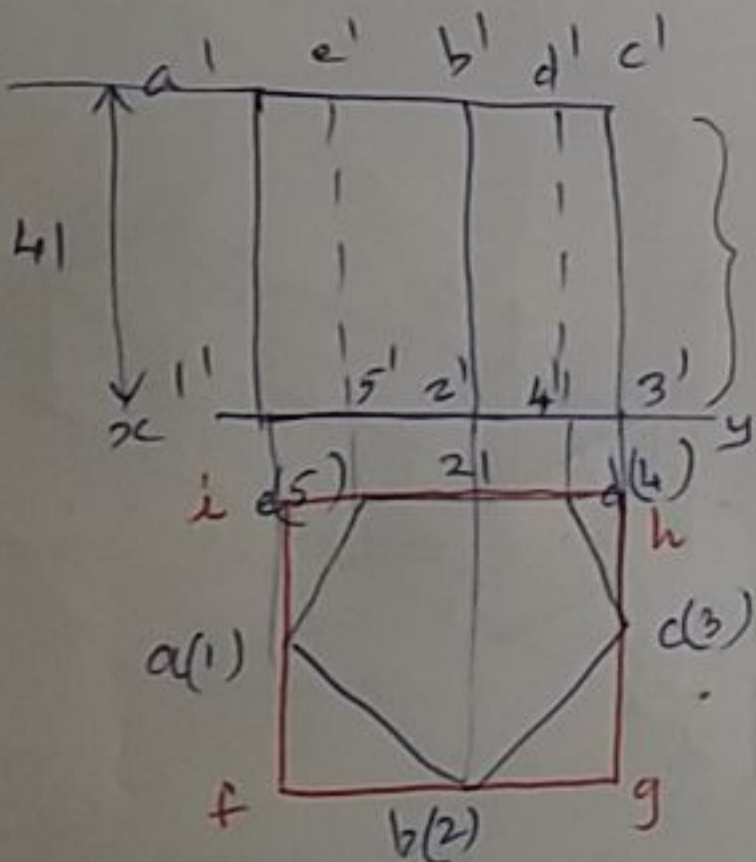
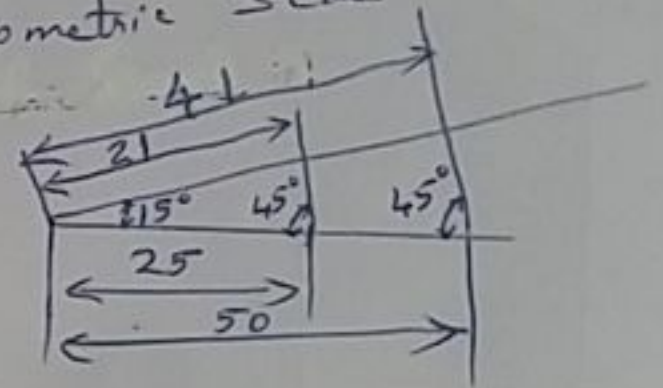

Orth. proj. using Iso. Scale

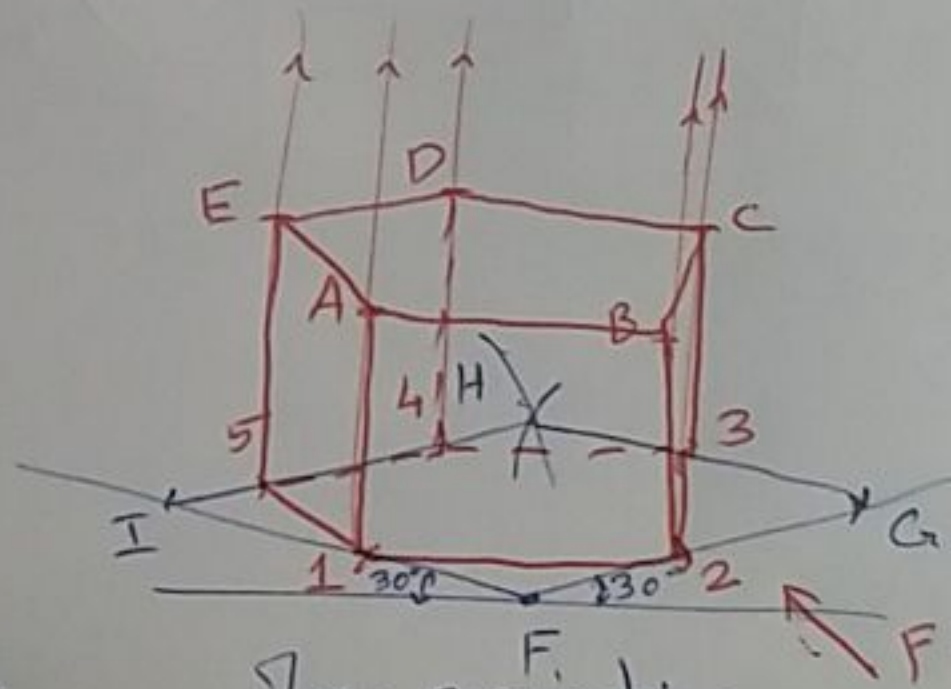

Iso. projection.